

Operating Manual Axio Scope.A 1

Microscope for Routine and Entry-Level Research

A thorough knowledge of these instructions is mandatory in order to operate the machine. Please familiarize yourself with the content and follow the safety instructions by all means.

We reserve the right to make changes in the interest of further technical development. The manual is not subject to updating.

© Passing on and reproduction of this document, utilization and notice of its content are not permitted unless explicitly allowed. Noncompliance is bound to indemnity.

All rights reserved, including rights created by patent grant or registration of a utility model or design.

Brands and names indicated in this manual may be trademarks of other companies. These brands and names are mentioned only for information and do not express any approval or recommendation by us.

Carl Zeiss MicroImaging GmbH cannot assume any liability for the performance or the use of these brands.

Published by: **Carl Zeiss MicroImaging GmbH**

PO Box 4041, D - 37030 Goettingen

Telephone: +49 551 5060 660

Telefax: +49 551 5060 464

E-mail: micro@zeiss.de

www.zeiss.de

Number of the manual: M60-2-0007 e

Issue date: Version 6 – 13-05-2008

CONTENT

	Page
1	INTRODUCTION 9
1.1	Safety Guidelines 9
1.2	Warranty 14
1.3	Stand Variants 15
1.4	Interface Diagram 17
1.5	Summary of the Controls and Functional Elements 19
2	TECHNICAL MANUAL 21
2.1	Intended Use 21
2.2	Systems Overview 22
2.3	Technical Data 27
3	STARTUP 29
3.1	Mounting the Standard Components 29
3.1.1	Unpacking and Mounting the Microscope Stand 29
3.1.2	Mounting the Upper Stand Part on the Stand Column 30
3.1.3	Mounting the Binocular Tube / Photo Tube 31
3.1.4	Inserting Eyepieces or an Auxiliary Microscope 31
3.1.5	Mounting Objectives 33
3.1.6	Installing and Uninstalling "Push&Click" Modules in the Reflector Insert 34
3.1.7	Mounting the Reflector Insert 35
3.1.8	Mounting the Mechanical Stage 36
3.1.9	Mechanical Stages with Friction Adjustment 39
3.1.10	Mounting the LED Illuminator for Transmitted Light 41
3.1.11	Mounting the Condenser Carrier 42
3.1.12	Mounting the Condenser 43
3.1.13	Mounting the Stage Carrier 44
3.1.14	Inserting the Halogen Lamp 12 V, 50 W 45
3.1.15	Halogen Lamp HAL 100 46
3.1.16	Inserting the Adjustment Aid into the Upper Stand Part FL/HBO 49
3.1.17	HBO 50 Illuminator 49
3.1.18	HBO 100 Illuminator 52
3.1.19	Illumination System Colibri and External Illumination Fixture HXP 120 53
3.2	Connection of the Power Supply 54
3.2.1	Lower Stand Part for LED and HAL 50 Illumination 54
3.2.2	Lower Stand Part for HAL 100 Illumination 54
3.2.3	Upper Stand Part for HAL 100/HBO, FL/HBO, FL-LED 55

3.3	Switching the Microscope and its Separate Illumination Fixtures on and off	55
3.4	Mounting Optional Components	56
3.4.1	Changing the Upper Stand Part and Inserting a Centerpiece for Larger Specimens	56
3.4.2	Mounting the Intermediate Plate for Analyzer Slider	57
3.4.3	Mounting the Tube Lens Turret	57
3.4.4	Mounting the Magnification Changer	58
3.4.5	Changing the Filters in the Reflector Module FL P&C	58
3.4.6	Changing the Color Splitter in the Reflector Module FL P&C	60
3.4.7	Mounting the Polarizer D or the Filter Holder	61
3.4.8	Mounting and Centering the Overview Fixture	62
3.4.9	Changing the LED Module in the Upper Stand Part FL-LED	63
3.4.10	Inserting a Modulator Disk in the Condenser 0.9/1.25 H	64
3.4.11	Changing the Diaphragm PlasDIC	65
3.4.12	Changing the Diaphragm Ph-DIC on the Achromatic-Aplanatic Condenser 0.9 H D Ph DIC	65
3.4.13	Changing the Filter in the Filter Wheel Transmitted Light	66
3.5	Default Setting of the Microscope	67
3.5.1	Adjusting the Eyepiece Distance (Distance of the Pupils) on the Binocular Tube	67
3.5.2	Adjusting the Viewing Height	67
3.5.3	Correction of Vision Defects with the Eyepiece Graticules	68
4	OPERATION	69
4.1	Illumination and Contrasting Method	69
4.1.1	Adjusting the Transmitted Light/Bright-Field According to KÖHLER	69
4.1.2	Adjusting the Transmitted Light/Dark-Field According to KÖHLER	72
4.1.3	Adjusting the Transmitted Light/Phase-Contrast	74
4.1.4	Adjusting the Transmitted Light/Differential Interference Contrast (DIC)	76
4.1.5	Adjusting PlasDIC-Contrast in Transmitted Light	78
4.1.6	Adjusting Transmitted Light/Polarization	79
4.1.7	Adjusting the Reflected Light/Bright-Field According to KÖHLER	83
4.1.8	Adjusting the Reflected Light/Dark-Field	86
4.1.9	Adjusting Reflected Light DIC and Reflected Light C-DIC	87
4.1.10	Adjusting Reflected Light TIC	88
4.1.11	Adjusting Reflected Light Polarization – Proof of Bireflexion and Reflexion pleochroism ...	91
4.1.12	Adjusting Reflected Light Fluorescence	93
4.2	Operating and Functional Elements of Optional Components	95
4.2.1	Lower Stand Part for LED Transmitted Light Illumination	95
4.2.2	Lower Stand Part with HAL 50 Illumination	96
4.2.3	Lower Stand Part for HAL 100 Illumination	97
4.2.4	Stand Column Vario 380 mm or 560 mm with Gear Box	98
4.2.5	Upper Stand Part Transmitted Light	99
4.2.6	Upper Stand Part FL/HBO	99
4.2.7	Upper Stand Part FL-LED	100
4.2.8	Upper Stand Part HAL 100/HBO	101

4.2.9	Upper Stand Part HAL 100/HBO DIC	101
4.2.10	Sideport ISCP T60N Left	102
4.2.11	Reflector Slider 2-fold	103
4.2.12	Reflector Turret 4-fold or 6-fold	103
5	MAINTENANCE, CHANGING OF FUSES AND SERVICE	109
5.1	Maintenance.....	109
5.2	Technical Service	110
5.2.1	Check-Up	110
5.2.2	Changing the Fuses	110
5.3	Trouble Shooting	111
5.4	Service.....	114
6	ANNEX	115
6.1	List of Abbreviations	115
6.2	Subject Index.....	117
6.3	Property Rights	121

FIGURES

Fig. 1-1	Caution sign on lower stand part for HAL 100- and HAL 50-illumination	13
Fig. 1-2	Caution sign on upper stand part FL-LED	13
Fig. 1-3	Interface diagram (upper stand part FL/HBO and lower stand part with HAL 50 illumination)	18
Fig. 1-4	Summary of the controls and functional elements	20
Fig. 3-1	Setting up the microscope	29
Fig. 3-2	Mounting the upper stand part on the stand column	30
Fig. 3-3	Mounting the binocular tube	31
Fig. 3-4	Inserting eyepieces	31
Fig. 3-5	Inserting an eyepiece graticule	32
Fig. 3-6	Mounting objectives	33
Fig. 3-7	Changing the reflector module in the reflector insert	34
Fig. 3-8	Changing the reflector module in the upper stand part FL-LED	34
Fig. 3-9	Mounting the reflector insert	35
Fig. 3-10	Changing the stable mechanical stage	36
Fig. 3-11	Changing the rotatable mechanical stage	36
Fig. 3-12	Centering the rotatable mechanical stage	37
Fig. 3-13	Adjusting ergonomic drive	38
Fig. 3-14	Adjusting the frictional momentum	39
Fig. 3-15	Adjusting the connecting rod position for the ergo drive	40
Fig. 3-16	Mounting the LED illuminator on the condenser	41
Fig. 3-17	Connecting the LED illuminator	41
Fig. 3-18	Mounting the condenser carrier	42
Fig. 3-19	Mounting the condenser	43
Fig. 3-20	Mounting the stage carrier	44
Fig. 3-21	Removing a halogen lamp HAL 50	45
Fig. 3-22	Inserting a halogen lamp 12 V, 50 W	45
Fig. 3-23	Mounting the halogen lamp HAL 100	46
Fig. 3-24	Adjusting a halogen lamp HAL 100	47
Fig. 3-25	Changing a halogen lamp	48
Fig. 3-26	Inserting the adjustment aid	49
Fig. 3-27	Opening the HBO 50	49
Fig. 3-28	Changing the burner	50
Fig. 3-29	Mounting the HBO 50	51
Fig. 3-30	Adjusting the HBO 50	51
Fig. 3-31	Mounting the HBO 100	52
Fig. 3-32	Transformer HBO 100 W	52
Fig. 3-33	Adjustment aid	53
Fig. 3-34	Adjusting the HBO 100	53
Fig. 3-35	Lower stand part for HAL 50 illumination (proceed analogically for LED illumination)	54
Fig. 3-36	Lower stand part for HAL 100 illumination	54
Fig. 3-37	Auxiliary power supply unit HAL 100 (front and back)	55
Fig. 3-38	Transformer HBO 100 W (front and back)	55
Fig. 3-39	Changing the upper stand part, inserting a centerpiece	56
Fig. 3-40	Mounting the binocular tube	57

Fig. 3-41	Mounting the magnification changer	58
Fig. 3-42	Changing the filters in the reflector module FL P&C.....	58
Fig. 3-43	Mounting the filters and the color splitter	59
Fig. 3-44	Opening the module	60
Fig. 3-45	Changing the color filter	60
Fig. 3-46	Labeling the color splitter	61
Fig. 3-47	Mounting the polarizer D	61
Fig. 3-48	Mounting the overview fixture	62
Fig. 3-49	Changing the LED module	63
Fig. 3-50	Modulator disk in condenser 0.9/1.25 H.....	64
Fig. 3-51	Mounting the slit-diaphragm.....	65
Fig. 3-52	Changing the diaphragm Ph-DIC.....	65
Fig. 3-53	Changing the filter in the filter wheel transmitted light.....	66
Fig. 3-54	Adjusting the eyepiece distance on the binocular tube	67
Fig. 3-55	Adjusting the viewing height on the binocular tube	67
Fig. 4-1	Microscope adjustment in transmitted light/bright-field	70
Fig. 4-2	Adjusting the vertical stop on the condenser carrier.....	71
Fig. 4-3	Adjusting the vertical stop on the focusing drive.....	71
Fig. 4-4	Centering the dark-field diaphragm on the condenser, achromatic-aplanatic 0.9 H D Ph DIC.....	73
Fig. 4-5	Centering the annular phase diaphragm (light-colored, in the condenser) and the phase ring (dark-colored, in the object)	75
Fig. 4-6	Components for the transmitted light/DIC method.....	77
Fig. 4-7	Components for transmitted light polarization	79
Fig. 4-8	Determination of the polarization direction n_{γ} in a synthetic fiber	80
Fig. 4-9	Diagram of the color tables according to Michel-Lévy	81
Fig. 4-10	External auxiliary power supply unit for HAL 100	83
Fig. 4-11	Adjusting the microscope in the reflected light/bright-field	85
Fig. 4-12	Compensator compartment 6x20 with C-DIC slider 6x20	87
Fig. 4-13	TIC slider 6x20	88
Fig. 4-14	Interference stripes.....	89
Fig. 4-15	Components for reflected light polarization	92
Fig. 4-16	Components for reflected light fluorescence	94
Fig. 4-17	Lower stand part for LED transmitted light illumination	95
Fig. 4-18	Lower stand part with HAL 50 illumination.....	96
Fig. 4-19	Lower stand part for HAL 100 illumination	97
Fig. 4-20	Stand column Vario.....	98
Fig. 4-21	Upper stand part transmitted light	99
Fig. 4-22	Upper stand part FL/HBO.....	99
Fig. 4-23	Upper stand part FL-LED.....	100
Fig. 4-24	Upper stand part HAL 100/HBO	101
Fig. 4-25	Upper stand part HAL 100/HBO DIC	101
Fig. 4-26	Sideport ISCP T60N left.....	102
Fig. 4-27	Reflector slider 2-fold	103
Fig. 4-28	Reflector turret 6-fold	103
Fig. 4-29	Condenser 0.9/1.25 H with modulator disk	104
Fig. 4-30	Nosepiece with compartment for compensators.....	104
Fig. 4-31	Binocular ergo tube.....	105

Fig. 4-32	Binocular photo tube	106
Fig. 4-33	Adjusting the viewing height on the binocular tube	106
Fig. 4-34	Mechanical stage with object holder	107
Fig. 4-35	Overview fixture	107
Fig. 4-36	Diaphragm slider 14x40 mm	108
Fig. 5-1	Changing the fuses on the stand.....	110

1 INTRODUCTION

1.1 Safety Guidelines

The microscopes Axio Scope.A1 were engineered, manufactured and tested according to DIN EN 61010-1 (IEC 61010-1) and IEC 61010-2-101, safety regulations for metering, control and laboratory equipment.

The microscopes fulfill the requirements as stated in regulation 98/79/EG (In-Vitro-Diagnostika) and carry the label .

The present manual gives information and safety warnings which must be followed by the operator.

The following warning and instruction icons are used in the manual:

**CAUTION**

Warns the operator of a possible danger.

**CAUTION**

Hot surface!

**CAUTION**

UV radiation!

**BE CAREFUL, LED radiation!**

*LED class 3B, max. 30 mW, 365 - 625 nm,
Avoid direct exposure to the beam. Avoid contact with the skin!*

**CAUTION**

Pull the plug before handling the instrument!

**CAUTION**

Possible danger for the instrument or the system.

**ATTENTION**

Points out instructions which should be followed carefully.

The microscope Axio Scope.A1 and its genuine accessories may only be used for microscopy methods as indicated in this manual.

The following guidelines are especially important:



The manufacturer admits no liability if the microscope, its components or single parts, are used in any different manner. Liability is also excluded for any service or repair work performed by non-authorized personnel and any rights to claims under guarantee expire.



The microscope may only be plugged into an electrical outlet equipped with a safety contact. The safety aspect must not be disabled by using an extension cord which does not have a ground wire.



Whenever it becomes apparent that any of the safety mechanisms is out of order, the microscope must be switched off and protected from any accidental use. Please contact the Zeiss Service Department or the Carl Zeiss Microscopy Service before switching the microscope on again.



The lower stand parts for LED illumination and those with integrated HAL 50 illumination are equipped with a power supply unit integrated in the stand. This unit adapts to a voltage range of 100 to 240 V $\pm 10\%$, 50 / 60 Hz, no further voltage adjustment is necessary on the microscope itself.



The auxiliary power supply unit SNT 12 V DC 100 W for HAL 100 covers a voltage range from 100 to 240 V AC $\pm 10\%$, 50 to 60 Hz. It adapts automatically to the applied voltage. The transformers for the HBO 100 adapt to a voltage range from 100 to 240 V AC, 50 to 60 Hz. They adapt automatically to the applied voltage. No further voltage adjustment is necessary.

However, the transformer for the HBO 50 must be adjusted according to the applied voltage (100, 110, 120, 127 or 230, 240 V). Please do not forget to adjust the power frequency accordingly (50 or 60 Hz).

Before you switch on the microscope, please verify that the voltage you are about to use is suitable.



Always pull the plug before you open the microscope or change a fuse!



Please make sure that the fuses are suitable for the applied nominal current. Never use any makeshift fuses and do not short-circuit the fuse holders.



The microscopes Axio Scope.A1 do not have any special safety fixtures to protect from acid, potentially infectious, toxic, radioactive or other specimens potentially hazardous to your health.



All legal requirements, especially the national regulations for the prevention of accidents must be followed.



Gas discharge lamps, e.g. HBO 100, emit ultraviolet radiation which may cause eye and skin burns. Never look directly into the beam and avoid any direct skin exposure to the beam. Never operate the microscope without the necessary safety equipment (e.g. special damping filters or the fluorescence protection screen). Gas discharge lamps have a high internal pressure when hot. Never change the lamps while they are still hot and make sure to always use protective gloves and masks when changing them.



Microscope lamps radiate a lot of heat which could damage the heat sensitive fluorescence filters. It is therefore necessary not to remove the heat protection filter when using a fluorescence filter so that it can function properly.



Avoid any contact with the hot lamp case. Before you change a lamp, make sure to pull the plug and wait 15 minutes for the lamp to cool down.



Dirt and dust may affect the microscope's performance. Protect it by using a dust cover when it is not in use. Always make sure that the instrument is switched off before covering it up.



Covering the ventilation slits may accumulate heat which could damage the instrument and even start a fire. Make sure to keep the ventilation slits open and never put or accidentally drop anything into them.



Only authorized personnel should be allowed to operate the instruments. The personnel must be aware of the possible danger which might occur while using the microscope. The Axio Scope.A1 is a precision tool which can easily be damaged or even destroyed when handled improperly.



Never operate the instrument in an area with potentially explosive atmosphere. Always place it on a stable and heat resistant surface. Specimens must be disposed of appropriately according to valid legal regulations and internal work instructions.



When the lamp module (e.g. Colibri) is equipped with appropriate LED modules, or when a white light source coupled by a fluid light conductor is used, ultraviolet radiation may leak which can cause eye and skin burns. Never look directly into the light and avoid any direct skin exposure to the light. Always use the appropriate safety equipment when operating the microscope.



Never look into the light beam of the illumination equipment - with or without optical instruments. Not even if you just want to look at a specimen. Irreparable eye damage may occur!



Do not hold any flammable or easily combustible materials around the light beam.



Please read the safety data sheet on Immersol 518 N[®], Immersol 518 F[®] and Immersol W[®] carefully.



The immersion fluid Immersol 518 N[®] is irritant to the skin. Avoid any contact with skin, eyes and clothes.

If skin contact occurs, wash off with lots of water and soap.

If eye contact occurs, flush with water immediately for at least 5 minutes. Seek medical assistance if irritation continues.



Dispose of immersion fluid Immersol 518 N[®] appropriately: Do not allow to contaminate surface water or get into drains.



Defective microscopes do not belong in the household garbage. Follow the appropriate legal regulations for their disposal.

Specimens must also be disposed off appropriately according to valid legal regulations and internal work instructions.



Caution signs on lower stand part for HAL 100- and HAL 50-illumination and on upper stand part FL-LED

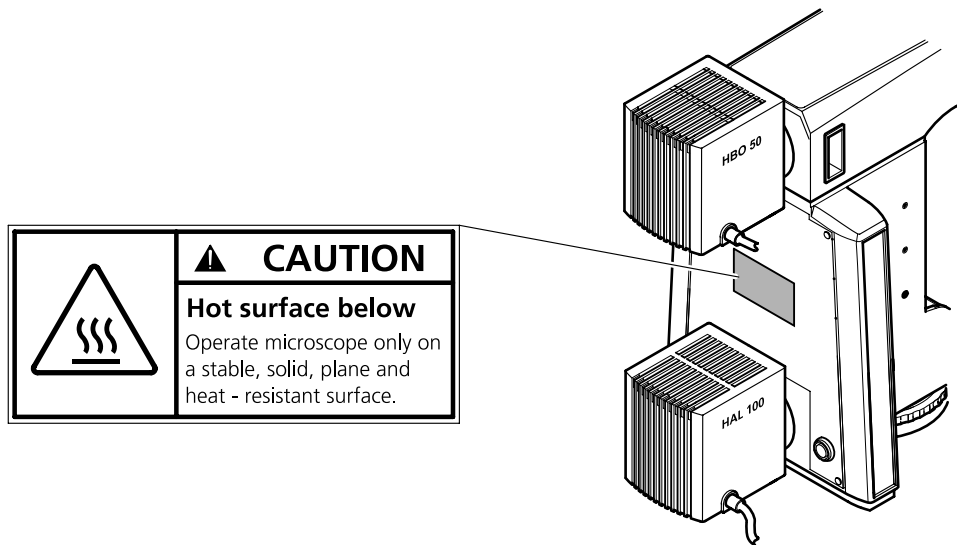

Fig. 1-1 Caution sign on lower stand part for HAL 100- and HAL 50-illumination

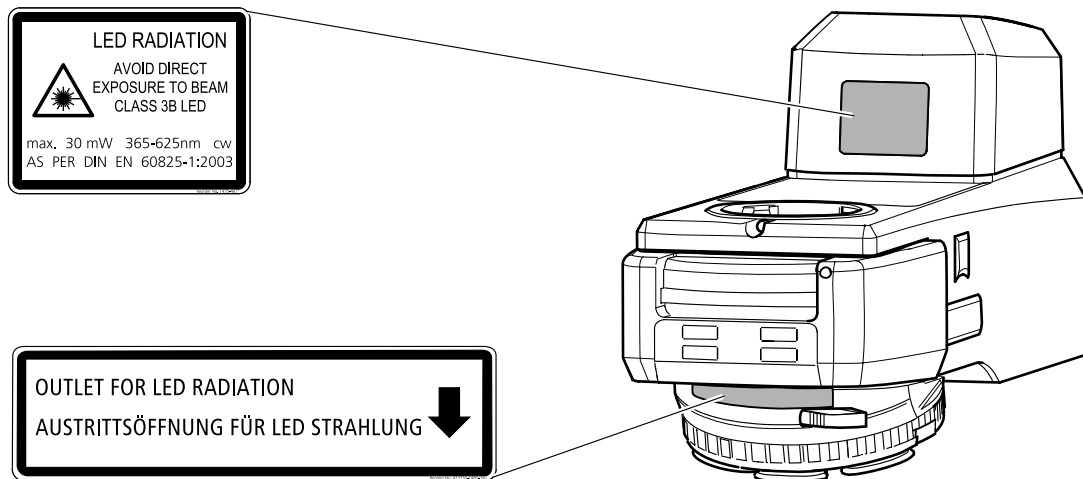

Fig. 1-2 Caution sign on upper stand part FL-LED

1.2 Warranty

The manufacturer guarantees that the instrument is free of any material and workmanship defects upon delivery. If you become aware of any deficiencies, please contact us immediately and take all necessary precautions in order to avoid further damage. Upon notice of deficiencies it is up to the manufacturer's discretion to correct the deficiencies or to deliver a defect-free instrument. Defects due to ordinary wear and tear (especially on wearing parts) and to improper handling are not covered by our warranty.

The manufacturer is not responsible for damages to the instrument which occur by maloperation, negligence or any other manipulation of the instrument, especially if the damages occur while removing or changing any parts or when using accessories from other manufacturers. This will immediately void the warranty.

No maintenance or repair work, except for the instances mentioned in the manual, may be performed on the microscopes. Only Carl Zeiss service personnel or personnel authorized especially by Carl Zeiss may perform repair work on the microscopes. If your instrument happens to malfunction please contact the Carl Zeiss Microscopy Service Department, Germany, (see p. 114) or the Carl Zeiss agency assigned to your country.

1.3 Stand Variants

The shipment includes five different upper stand parts, three lower stand parts and two stand columns which can be combined according to the following chart.

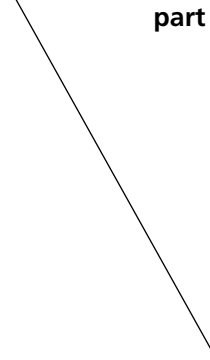
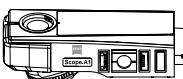
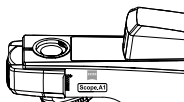
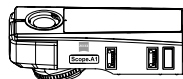
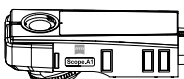
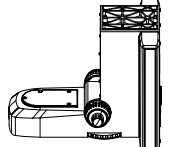
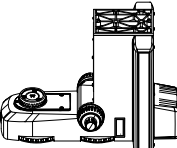
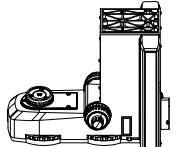
<p>Upper stand part</p>  <p>Lower stand part</p>	<p>Upper stand part Backlight with nosepiece 6x bright field, M27</p> 	<p>Upper stand part FL/HBO with nosepiece 3x bright field, 3x DIC, M27</p> 	<p>Upper stand part FL-LED with nosepiece 3x bright field, 3x DIC, M27</p> 	<p>Upper stand part HAL 100/HBO with nosepiece 6x bright/dark field, M 27</p> 	<p>Upper stand part HAL 100/HBO with nosepiece 6x bright/dark field, DIC, M27</p> 
<p>Lower stand part for LED illumination</p> 	<p>Microscope stand "Axio Scope.A1 " LED, 6x H</p> <p>430035-9200-000</p>	<p>Microscope stand "Axio Scope.A1 " LED, FL/HBO, 3x H, 3x DIC</p> <p>430035-9210-000</p>	<p>Microscope stand "Axio Scope.A1 " LED, FL-LED, 3x H, 3x DIC</p> <p>430035-9220-000</p>	<p>Microscope stand "Axio Scope.A1 " LED, HAL 100/HBO, 6x HD</p> <p>430035-9080-000</p>	<p>Microscope stand "Axio Scope.A1 " LED, HAL 100/HBO, 6x HD DIC</p> <p>430035-9090-000</p>
<p>Lower stand part for HAL 50 illumination</p> 	<p>Microscope stand "Axio Scope.A1 " HAL 50, 6x H</p> <p>430035-9030-000</p>	<p>Microscope stand "Axio Scope.A1 " HAL 50, FL/ HBO, 3x H, 3x DIC</p> <p>430035-9040-000</p>	<p>Microscope stand "Axio Scope.A1 " HAL 50, FL-LED, 3x H, 3x DIC</p> <p>430035-9050-000</p>	<p>Microscope stand "Axio Scope.A1 " HAL 50, HAL 100/HBO, 6x HD</p> <p>430035-9100-000</p>	<p>Microscope stand "Axio Scope.A1 " HAL 50, HAL 100/HBO, 6x HD DIC</p> <p>430035-9110-000</p>
<p>Lower stand part for HAL 100 illumination</p> 	<p>Microscope stand "Axio Scope.A1 " HAL 100, 6x H</p> <p>430035-9130-000</p>	<p>Microscope stand "Axio Scope.A1 " HAL 100, FL/HBO, 3x H, 3x DIC</p> <p>430035-9060-000</p>	<p>Microscope stand "Axio Scope.A1 " HAL 100, FL-LED, 3x H, 3x DIC</p> <p>430035-9070-000</p>	<p>Microscope stand "Axio Scope.A1 " HAL 100, HAL 100/HBO, 6x HD</p> <p>430035-9140-000</p>	<p>Microscope stand "Axio Scope.A1 " HAL100, HAL 100/HBO, 6x HD DIC</p> <p>430035-9120-000</p>

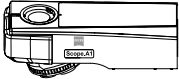
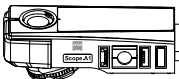
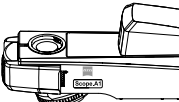
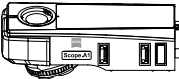
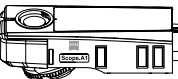
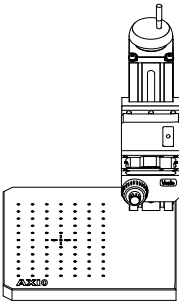
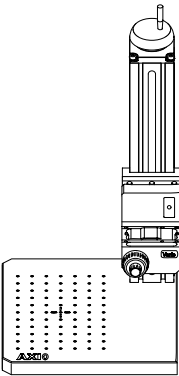
<p>Upper stand part</p> <p>Lower stand part</p>	<p>Upper stand part Backlight with nosepiece 6x bright field, M27</p> 	<p>Upper stand part FL/HBO with nosepiece 3x bright field, 3x DIC, M27</p> 	<p>Upper stand part FL-LED with nosepiece 3x bright field, 3x DIC, M27</p> 	<p>Upper stand part HAL 100/HBO with nosepiece 6x bright/dark field, M 27</p> 	<p>Upper stand part HAL 100/HBO with nosepiece 6x bright/dark field, DIC, M27</p> 
<p>Stand column "Axio Scope" Vario 380 mm</p> 		<p>Upper stand part "Axio Scope" FL/HBO, 3x H, 3x DIC, M27 423730-9030-000</p> <p>Stand column "Axio Scope" Vario 380 mm 451017-9010-00</p> <p>Focusing gear box "Axio Scope" Vario, focus lift 15 mm 430036-9000-000</p>	<p>Upper stand part "Axio Scope" FL-LED, 3x H, 3x DIC, M27 423730-9050-000</p> <p>Stand column "Axio Scope" Vario 380 mm 451017-9010-00</p> <p>Focusing gear box "Axio Scope" Vario, focus lift 15 mm 430036-9000-000</p>	<p>Upper stand part "Axio Scope" HAL 100/HBO, 6x HD, M27 423730-9060-000</p> <p>Stand column "Axio Scope" Vario 380 mm 451017-9010-000</p> <p>Focusing gear box "Axio Scope" Vario, focus lift 15 mm 430036-9000-000</p>	<p>Upper stand part "Axio Scope" HAL 100/HBO, 6x HD DIC, M27 423730-9070-000</p> <p>Stand column "Axio Scope" Vario 380 mm 451017-9010-000</p> <p>Focusing gear box "Axio Scope" Vario, focus lift 15 mm 430036-9000-000</p>
<p>Stand column "Axio Scope" Vario 560 mm</p> 		<p>Upper stand part "Axio Scope" FL/HBO, 3x H, 3x DIC, M27 423730-9030-000</p> <p>Stand column "Axio Scope" Vario 560 mm 451017-9000-000</p> <p>Focusing gear box "Axio Scope" Vario, focus lift 15 mm 430036-9000-000</p>	<p>Upper stand part "Axio Scope" FL-LED, 3x H, 3x DIC, M27 423730-9050-000</p> <p>Stand column "Axio Scope" Vario 560 mm 451017-9000-000</p> <p>Focusing gear box "Axio Scope" Vario, focus lift 15 mm 430036-9000-000</p>	<p>Upper stand part "Axio Scope" HAL 100/HBO, 6x HD, M27 423730-9060-000</p> <p>Stand column "Axio Scope" Vario 560 mm 451017-9000-000</p> <p>Focusing gear box "Axio Scope" Vario, focus lift 15 mm 430036-9000-000</p>	<p>Upper stand part "Axio Scope" HAL 100/HBO, 6x HD DIC, M27 423730-9070-000</p> <p>Stand column "Axio Scope" Vario 560 mm 451017-9000-000</p> <p>Focusing gear box "Axio Scope" Vario, focus lift 15 mm 430036-9000-000</p>

1.4 Interface Diagram

The following figure shows a diagram of the interfaces of the microscope stand. The combination upper stand part FL/HBO and lower stand part with HAL 50 illumination serves as demonstration.

The interfaces vary according to which upper or lower stand part has been chosen.

Legend of Fig. 1-3:

- 1 Tube
- 2 Achromatic illumination adapter
- 3 Upper stand part
- 4 Filter slider reflected light
- 5 Adjustment aid
- 6 Adapter
- 7 Reflector insert
- 8 Lower stand part
- 9 Filter slider transmitted light
- 10 Filter in the filter wheel transmitted light
- 11 Condenser carrier
- 12 Condenser
- 13 Stage carrier
- 14 Stage

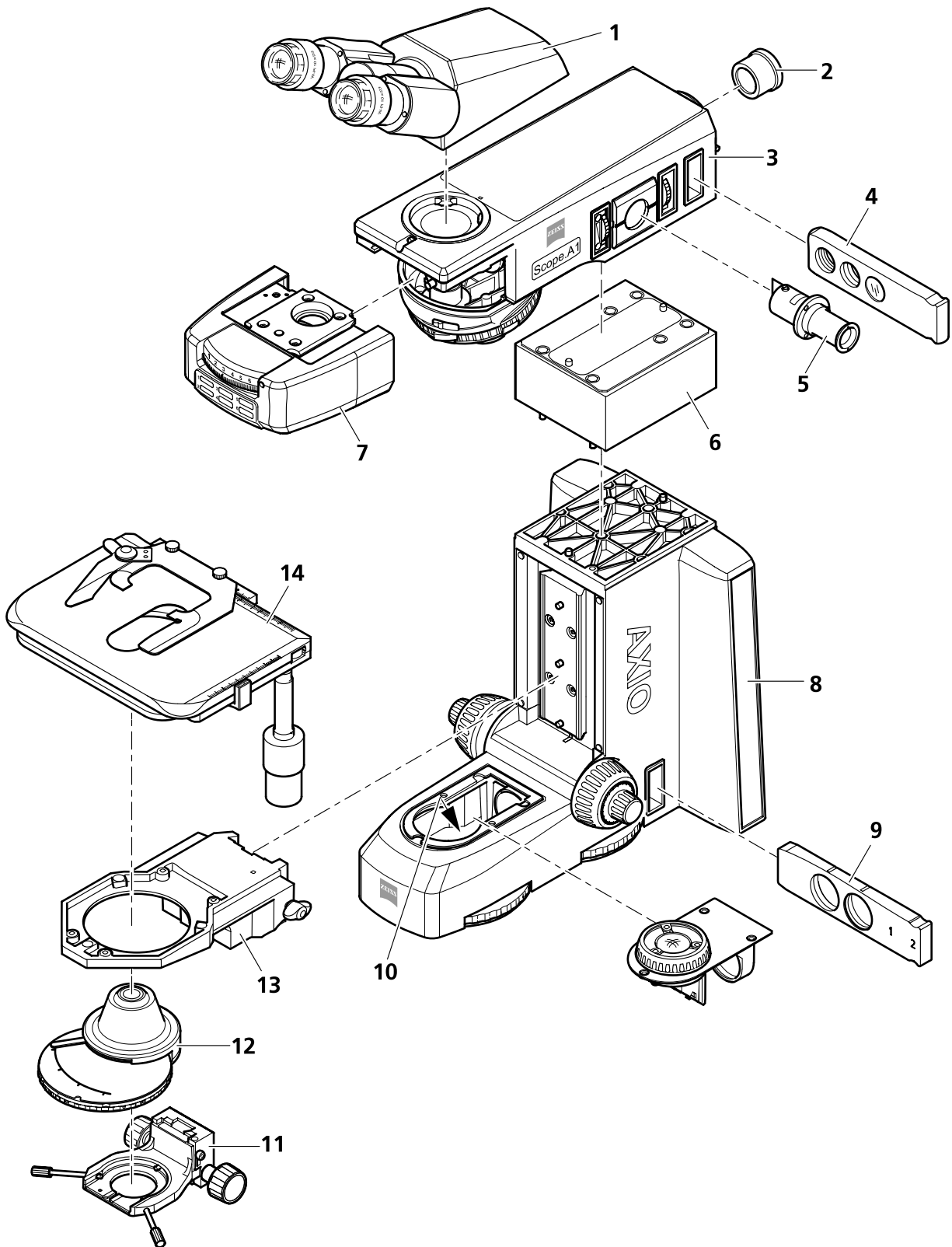

Fig. 1-3 Interface diagram (upper stand part FL/HBO and lower stand part with HAL 50 illumination)

1.5 Summary of the Controls and Functional Elements

Legend of Fig. 1-4:

- 1 Eyepieces
- 2 Binocular tube part
- 3 Field diaphragm (non removable or as slider)
- 4 Adjustment aid (on upper stand part FL/HBO only)
- 5 Aperture diaphragm (non-removable or as slider) or FL attenuator
- 6 Reflected light lamp
- 7 Filter slider reflected light
- 8 Transmitted light lamp
- 9 Filter slider transmitted light
- 10 Gear shift for diffusion disk (for lower stand part with HAL 100 illumination only)
- 11 Focusing drive – fine adjustment (both ways)
- 12 Focusing drive – rough adjustment (both ways)
- 13 Light intensity control (operable from both sides)
- 14 Gear knob for adjusting the mechanical stage in direction X
- 15 Gear knob for adjusting the mechanical stage in direction Y
- 16 Gear knob for adjusting the condenser vertically (both sides)
- 17 Filter wheel six fold (operable from both sides, not available for lower stand part for LED illumination)
- 18 Centering screw for condenser (both sides)
- 19 Field diaphragm (not available for lower stand part for LED illumination)
- 20 Condenser with aperture diaphragm (with optional modulator disk)
- 21 Nosepiece
- 22 Reflector insert (changeable)
- 23 Gear shift for diffusion disk reflected light (not available on all upper stand parts)
- 24 On/off switch (not available on lower stand parts for HAL 100 illumination)
- 25 Release tractor for vertical stop on focusing drive

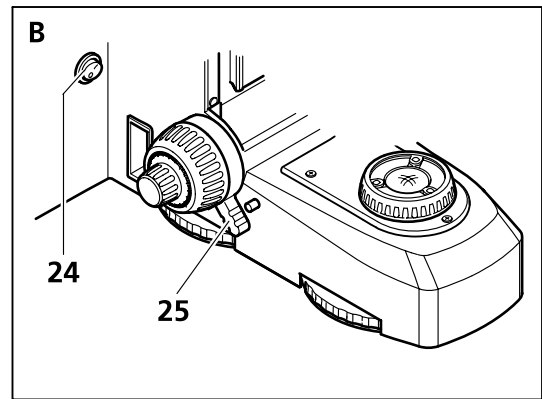
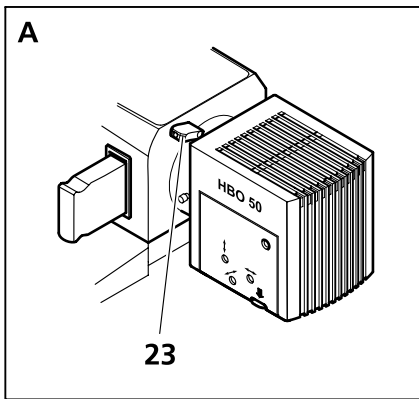
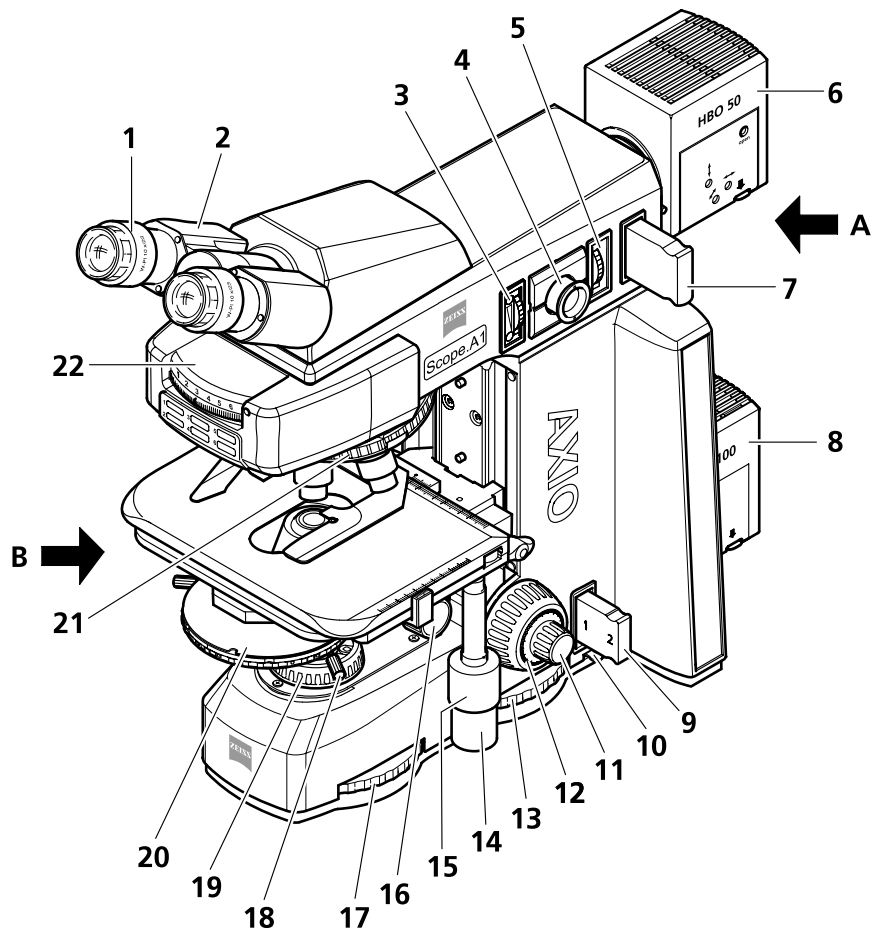

Fig. 1-4 Summary of the controls and functional elements

2 TECHNICAL MANUAL

2.1 Intended Use

The microscopes Axio Scope.A1 are universal microscopes designed especially for applications in biological and medical fields and for material studies.

Depending on the configuration of the microscope stand, they may be used with overhead or transmitted light only or with a combination of both.

The Axio Scope.A1 may be used in typical biomedical application fields such as:

- Medical exams in laboratories (research), hospitals, doctors' offices,
- Science and research (colleges, universities) in medical and biological fields,
- Industrial applications (pharmacology, food technology).

The Axio Scope.A1 may also be used for material studies in:

- Metallographic laboratories,
- Motor vehicle industry and
- Microsystems technology.

Depending on the accessories for each instrument the following microscopy and contrasting methods can be performed:

Transmitted light

- Bright field (H)
- Dark field (D)
- Phase-contrast (Ph)
- Differential interference contrast (DIC)
- PlasDIC
- Polarization (Pol)

Reflected light

- Bright field (H)
- Dark field (D)
- Differential interference contrast (DIC)
- C-DIC / TIC
- Fluorescence
- Polarization (Pol)

With a special adapter the binocular phototubes can be connected either with a microscopy camera, a reflex camera or a digital/video camera for documentation purposes. An ISCP camera can be used when working with transmitted light.

2.2 Systems Overview

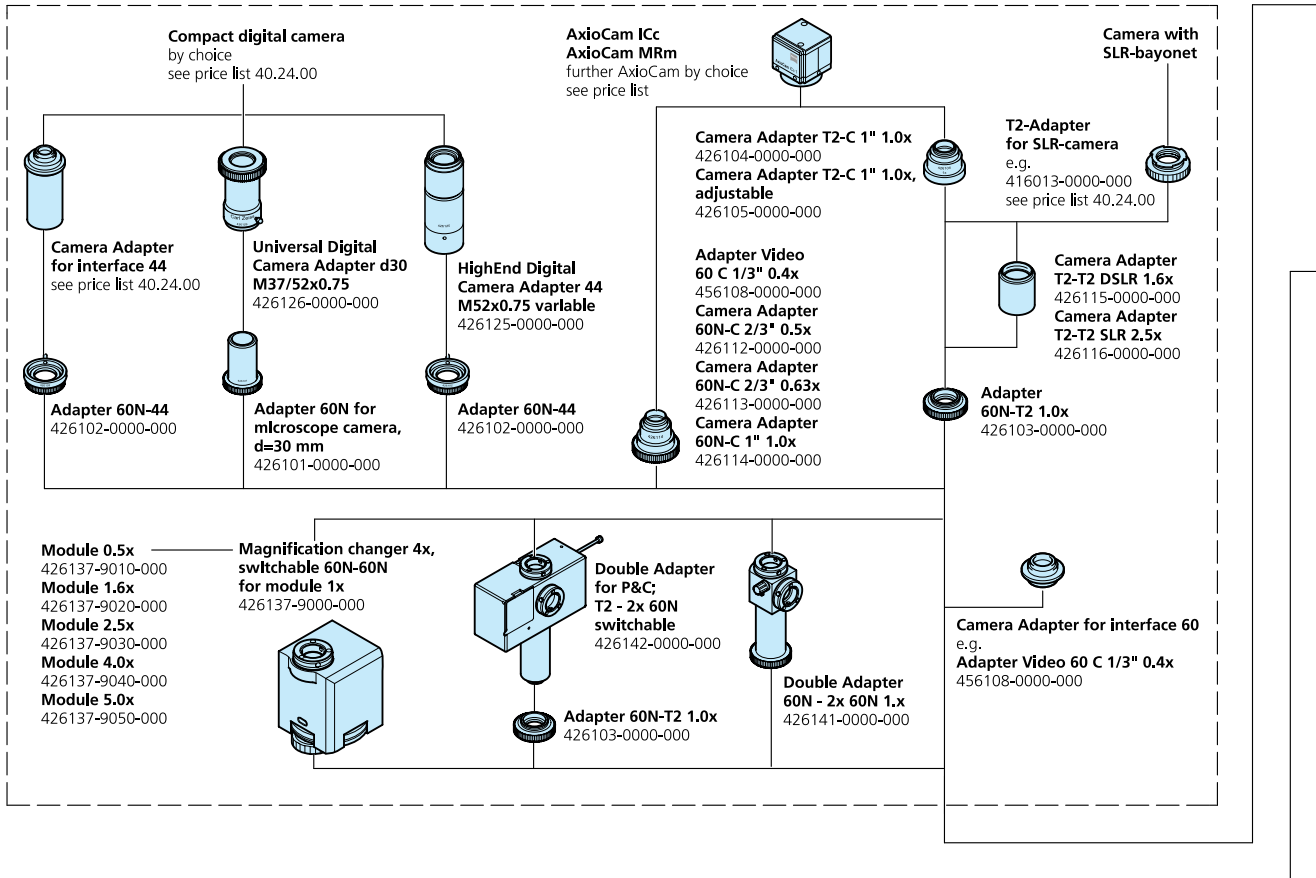

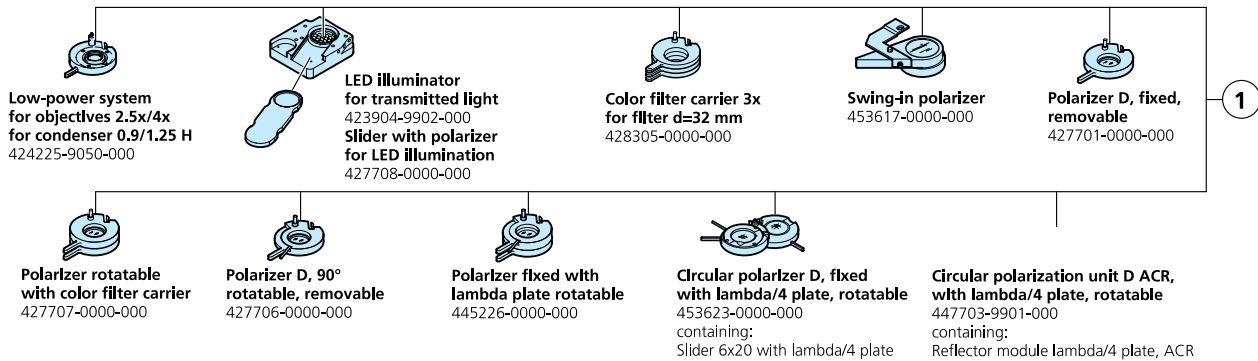
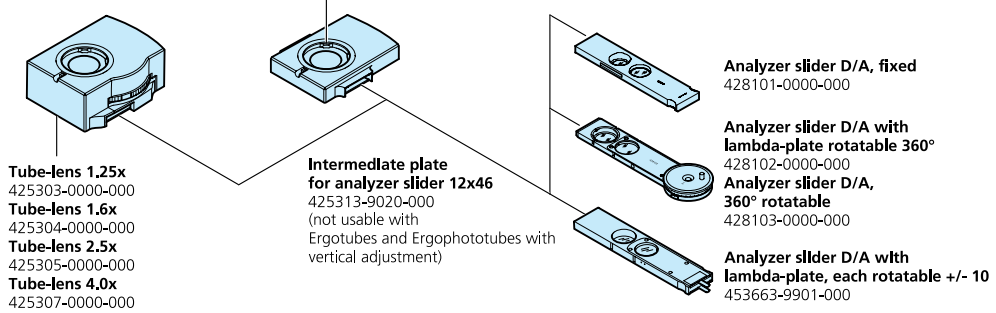

3-position tube-lens turret with tube-lens 1x
425313-9010-000
(only usable with the tubes:
425500-0000-000
425501-0000-000
425503-9901-000
425515-0000-000
in combination with SF 23 eyepieces)

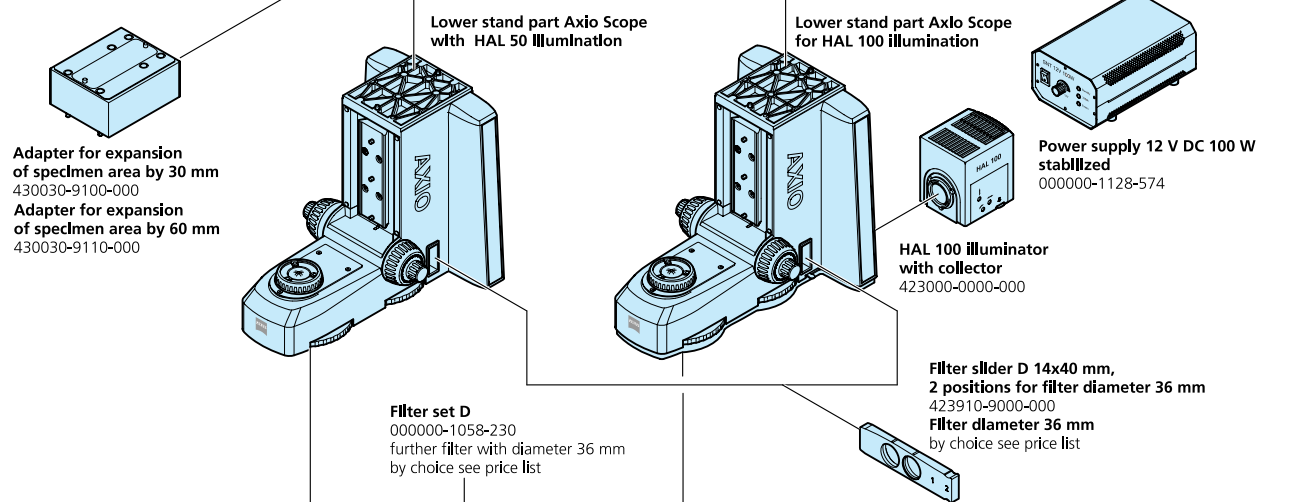
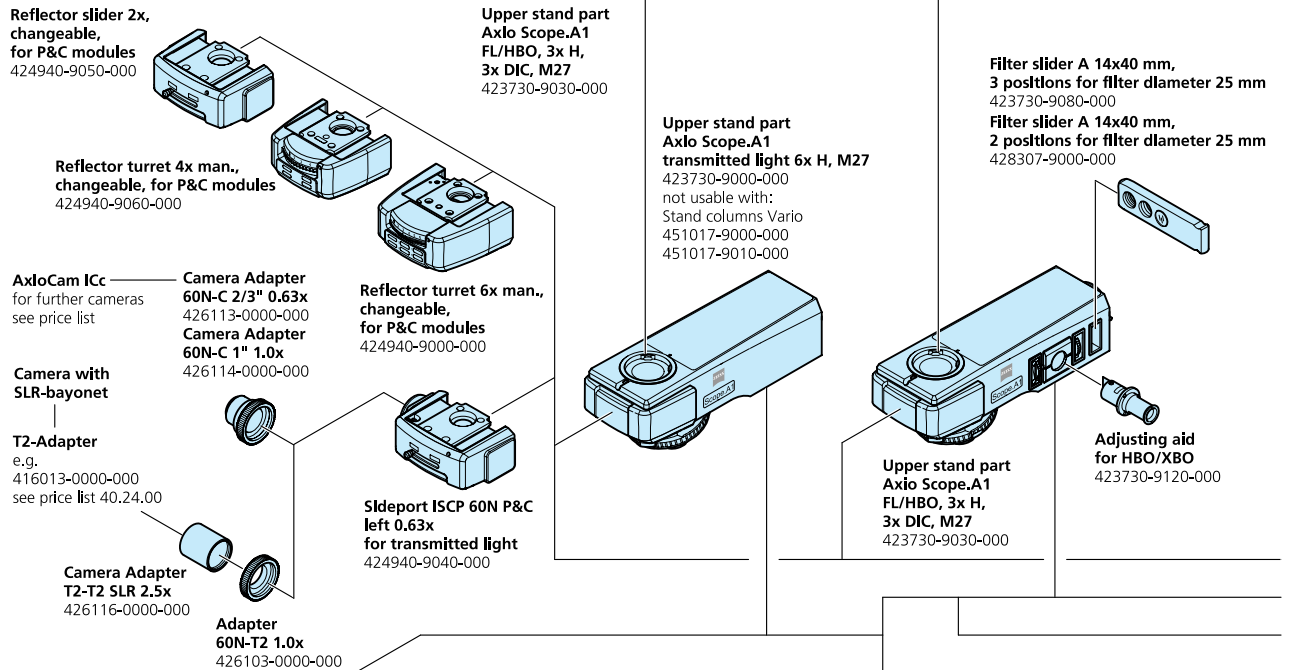
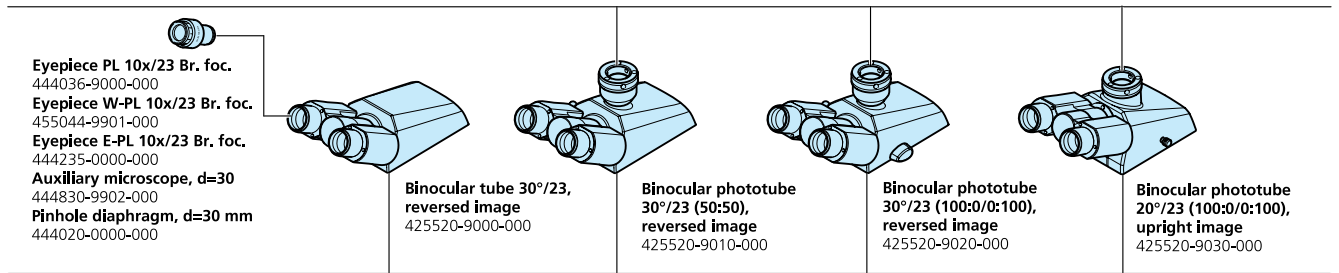

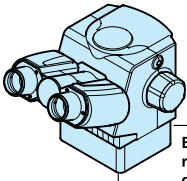
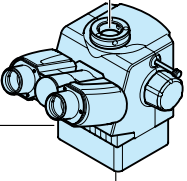
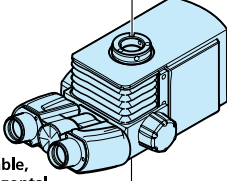

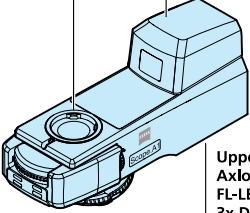
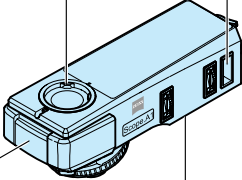
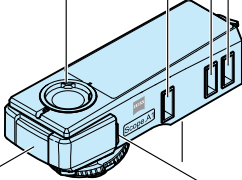
	<p>not usable with: Intermediate plate for analyzer slider 12x46 425313-9020-000</p>		<p>Binocular Ergophototube 20°/23 (100:0/0:100), reversed image variable, continuous vertical adjustment 44 mm 425512-0000-000</p> <p>Binocular Ergophototube 20°/23 MAT (100:0/0:100), upright image variable, continuous vertical adjustment 44 mm 425514-0000-000</p>	
<p>Binocular Ergotube 20°/23, reversed image variable, continuous vertical adjustment 44 mm 425511-0000-000</p>			<p>Binocular Ergophototube 15°/23 (50:50) vertically adjustable and extendable, upright image. Variable, continuous horizontal and vertical adjustment of the binocular component 425520-9050-000</p>	

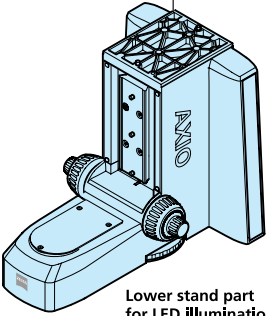
<p>LED module 365 nm 423052-9510-000</p> <p>LED module 625 nm 423052-9520-000</p> <p>LED module 615 nm 423052-9530-000</p> <p>LED module 590 nm 423052-9540-000</p> <p>LED module neutral white 540 - 580 nm 423052-9600-000</p>	<p>LED module 530 nm 423052-9550-000</p> <p>LED module 505 nm 423052-9560-000</p> <p>LED module 470 nm 423052-9570-000</p> <p>LED module 455 nm 423052-9580-000</p> <p>LED module 380 nm 423052-9590-000</p>	<p>Filter slider A 14x40 mm, 3 positions for filter diameter 25 mm 423730-9080-000</p> <p>Filter slider A 14x40 mm, 2 positions for filter diameter 25 mm 428307-9000-000</p>	<p>Stop slider A 14x40 mm with luminous-field diaphragm usable 423730-9100-000</p>	<p>Stop slider A 14x40 mm with aperture stop usable 423730-9150-000</p> <p>Slider 14x40 FL attenuator, discrete 423730-9130-000</p>	<p>Filter slider A 14x40 mm, 3 positions for filter diameter 25 mm 423730-9080-000</p> <p>Filter slider A 14x40 mm, 2 positions for filter diameter 25 mm 428307-9000-000</p>	<p>Polarizer slider A 6x30 mm, 90° rotatable 427710-9000-000</p>
						
<p>Upper stand part Axio Scope FL-LED, 3x, H, 3x DIC, M27 423730-9050-000</p>	<p>Upper stand part Axio Scope HAL 100/HBO, 6x HD, M27 423730-9060-000</p>	<p>Upper stand part Axio Scope HAL 100/HBO, 6x HD, DIC, M27 423730-9070-000</p>				

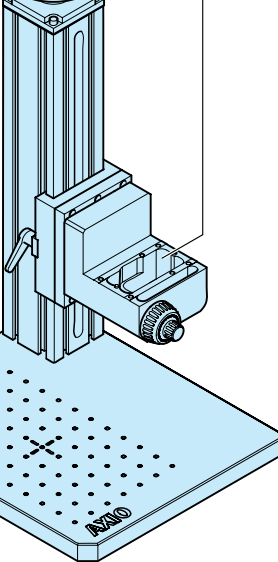
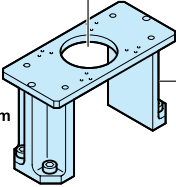
		<p>Stand column Axio Scope Varlo 380 mm 451017-9010-000</p> <p>Stand column Axio Scope Varlo 560 mm 451017-9000-000</p> <p>Focusing gear box Axio Scope Varlo, 15 mm focus lift 430036-9000-000</p>	
<p>Lower stand part for LED illumination</p>	<p>Dust protection Set M 434303-0000-000</p> <p>Dust protection Set L 434304-0000-000</p>		
	<p>Stages with length of drive < 140 mm can be used</p>		
	<p>Stage carrier H=140 mm for base plate 451016-9901-000</p>		

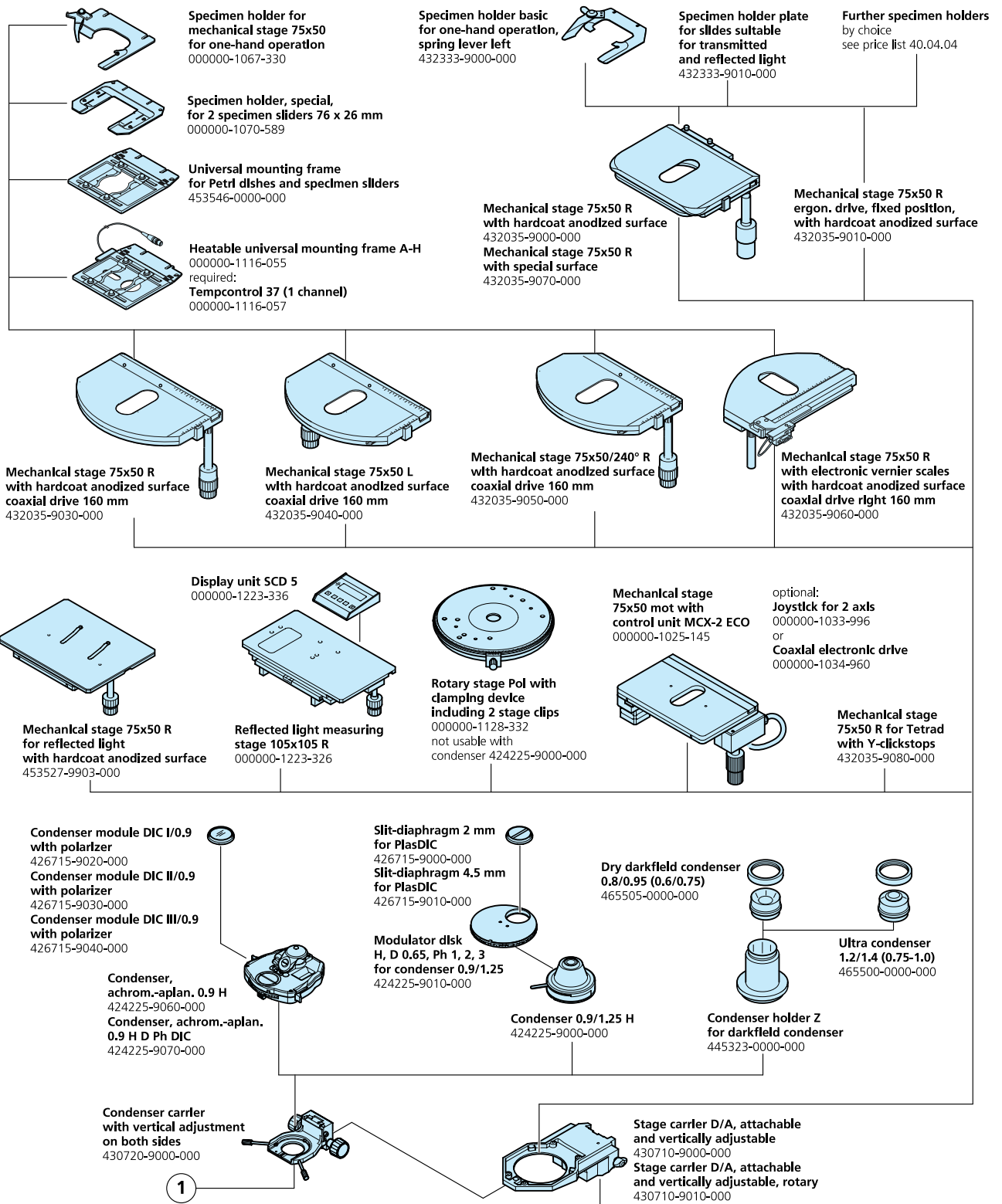

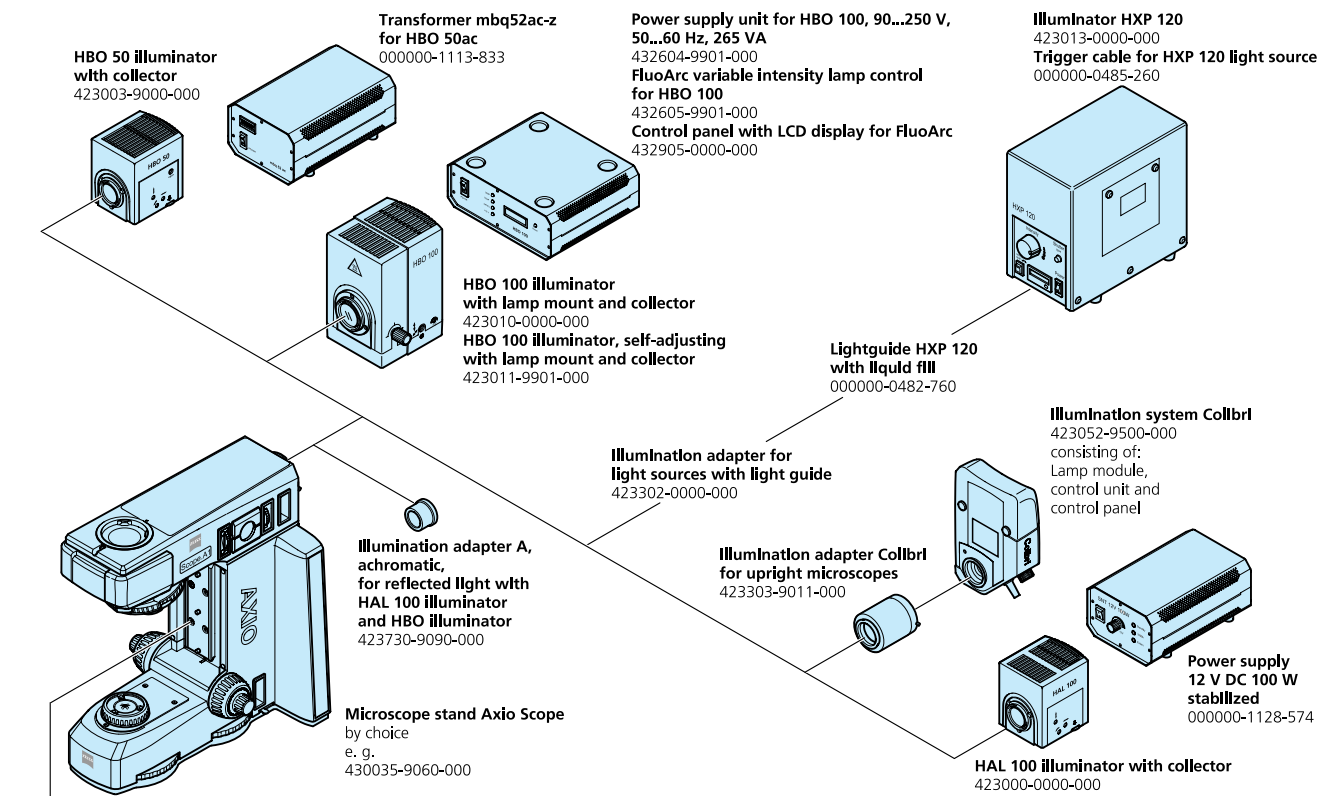
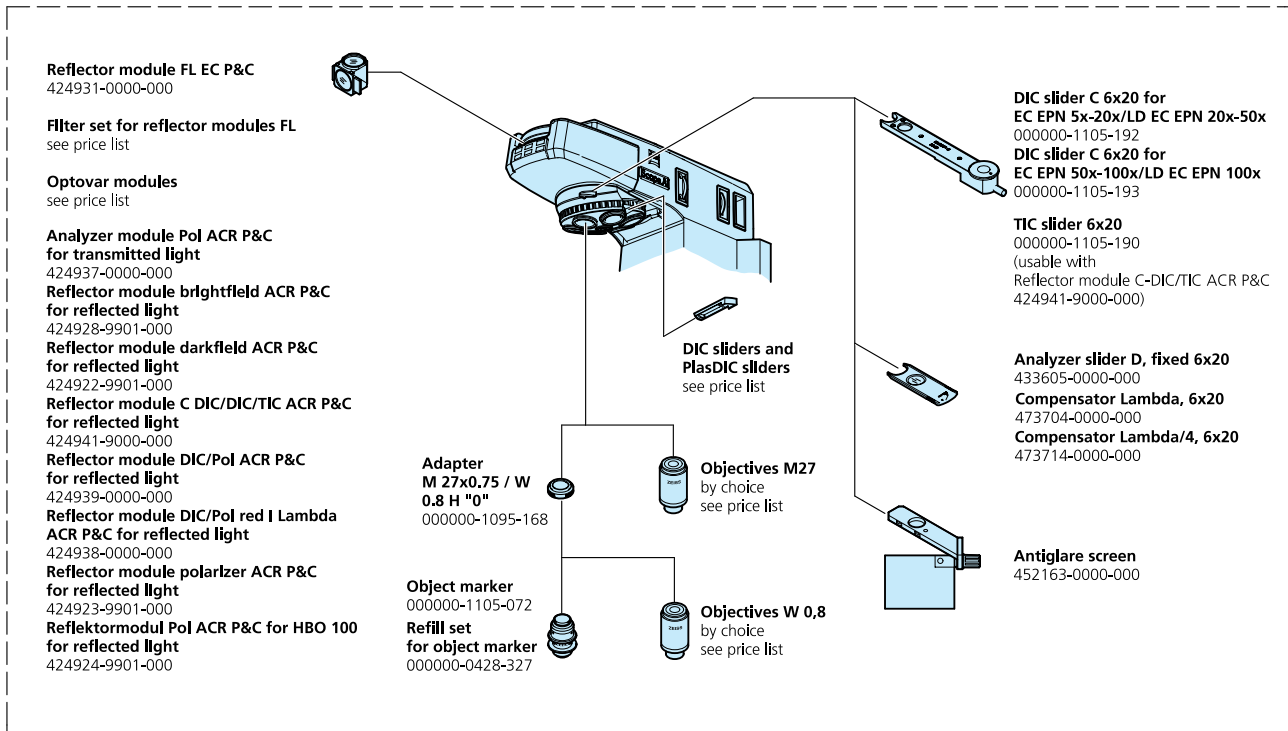

2.3 Technical Data

Dimensions (width x depth x height)

Microscope stand Axio Scope.A1 (no DL illumination)	approx. 240 mm x 340 mm x 365 mm
Stand column Vario 380 mm	approx. 460 mm x 390 mm x 465 mm
Stand column Vario 560 mm	approx. 460 mm x 390 mm x 645 mm

Mass

Microscope stand Axio Scope.A1 (depending on variant and accessories).....	approx. 14 to 20 kg
Stand column Vario	approx. 19 kg

Environmental conditions

Transport (in packaging):

Permissible environment temperature.....	-40 to +70 °C
--	---------------

Storage:

Permissible environment temperature.....	+10 to +40 °C
Permissible humidity (no condensation).....	max. 75 % at 35 °C

Operation:

Permissible environment temperature.....	-10 to +40 °C
Permissible relative humidity (no condensation).....	max. 75 % at 35 °C
Height of application.....	max. 2000 m
Air pressure.....	800 hPa to 1060 hPa
Pollution level.....	2

Operational data

Range of application.....	indoor
Protection class.....	I
Protection type	IP 20
Electrical security	according to DIN EN 61010-1 (IEC 61010-1) In consideration of CSA and UL regulations
Overvoltage category.....	II
Radio interference suppression	according to EN 55011 class B
Immunity.....	according to DIN EN 61326
Voltage range.....	100 to 240 V \pm 10 %, no voltage adjustment is necessary
Power frequency.....	50/60 Hz
Power input Axio Scope.A1 with internal power supply unit	110 VA
Power input Axio Scope.A1 with auxiliary power supply unit 12 V DC 100 W	220 VA

Transformer mbq52ac-z for HBO 50

Range of application.....	indoor
Protection class.....	I
Protection type	IP 20
Switchable voltage range.....	100, 110, 120, 127 VAC and 230, 240 VAC
Switchable power frequency.....	50 and 60 Hz
Power input with HBO 50 in operation	max. 350 VA

Transformer HBO 100 W

Range of application.....	indoor
Protection class.....	I
Protection type.....	IP 20
Voltage	100 VAC ... 240 VAC
Power frequency	50 ... 60 Hz
Power input with HBO 103 in operation	155 VA

Fuses according to IEC 127

Microscope stand Axio Scope.A1 for LED illumination in transmitted light	2x T 3.15 A/H, 5x20 mm
Microscope stand Axio Scope.A1 for HAL 50 illumination in transmitted light.....	2x T 3.15 A/H, 5x20 mm
Transformer mbq52ac-z for HBO 50.....	100 V, 127 V: 2x T 4 A
.....	220 V - 240 V: 2x T 2.5 A
Transformer HBO 100 W	T 2.0 A/H, 5x20 mm
Auxiliary power supply unit 12 V DC 100 W	2x T 5.0 A/H, 5x20 mm

Light sources

LED illumination DL

Power input.....	7 W
Halogen lamp.....	12 V / 50 W
Light source control	infinitely variable from approx. 3 to 12 V
Halogen lamp.....	12 V / 100 W
Light source control	infinitely variable from approx. 3 to 12 V
Mercury vapor short arc lamp	HBO 50
Power input for HBO 50.....	50 W
Mercury vapor short arc lamp	HBO 103 W/2
Power input for HBO 103 W/2	100 W
Illumination system Colibri	
Power input.....	70 W

Axio Scope.A1:

Stand with manual stage focusing

Rough drive	approx. 4 mm / rotation
Fine drive	approx. 0.4 mm / rotation; approx. 4 µm mark distance
Lift range	approx. 25 mm
Vertical stop.....	mechanically variable
Condenser 0.9/1.25 H with optional	
Modulator disk	for bright field, dark field and
.....	phase-contrast 1, 2, 3 or PlasDIC
Manual objective change	via nosepiece, 6-fold H, M27
Manual reflector module change	via reflector slider 2-fold,
.....	reflector turret 4-fold or 6-fold

3 STARTUP

The customer has the choice to either set up or mount the Axio Scope.A1 himself before putting it into operation, or have the Zeiss Customer Service do so for a fee.

 Please read the **Safety Guidelines** carefully before assembling and operating the microscope.

The assembly activities described in the following chapters are mainly based on the assembly of a microscope stand with an upper stand part and a lower stand part. The same activities apply when assembling a microscope stand with an upper stand part and the stand column Vario – special activities for the stand column Vario are described separately.

3.1 Mounting the Standard Components

3.1.1 Unpacking and Mounting the Microscope Stand

- Unpack all the components and check for completeness according to bill of loading.
- Set up the microscope stand (Fig. 3-1/1) on a vibration-free, plane, stable and non-flammable surface.
- We advise to keep the original packaging in case you want to store the instrument over a longer period of time or need to send it back to the manufacturer. If you want to dispose of the packaging, please do so in an appropriate manner.

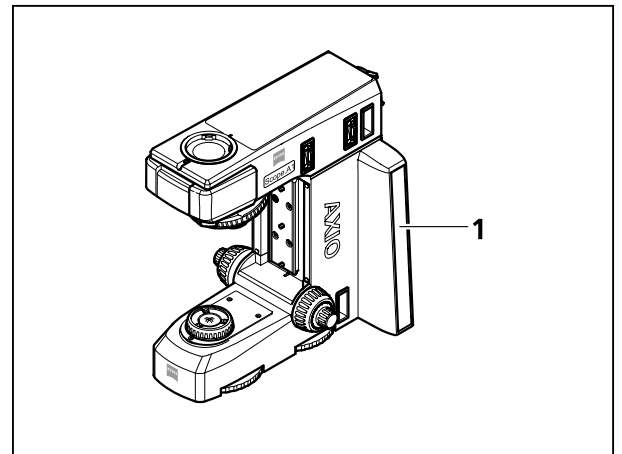

Fig. 3-1 Setting up the microscope

3.1.2 Mounting the Upper Stand Part on the Stand Column

If you are going to use a microscope stand consisting of an upper stand part and a stand column, please begin by assembling the upper stand part.

- Remove the magnetically mounted cover (Fig. 3-2/1) of the upper stand part by inserting a ball head screwdriver into the assembly opening in front (Fig. 3-2/3). Lift the cover.
- Using the six hexagon socket screws (Fig. 3-2/2) included in the package, screw the upper stand part (Fig. 3-2/4) onto the gear box (Fig. 3-2/5) of the stand column.
- Replace the cover.
- In order to adjust the microscope vertically, loosen both release tractors (Fig. 3-2/6) on the stand column and adjust the height (according to the size of the specimen) with the hand wheel (Fig. 3-2/7). Then tighten the release tractors again.

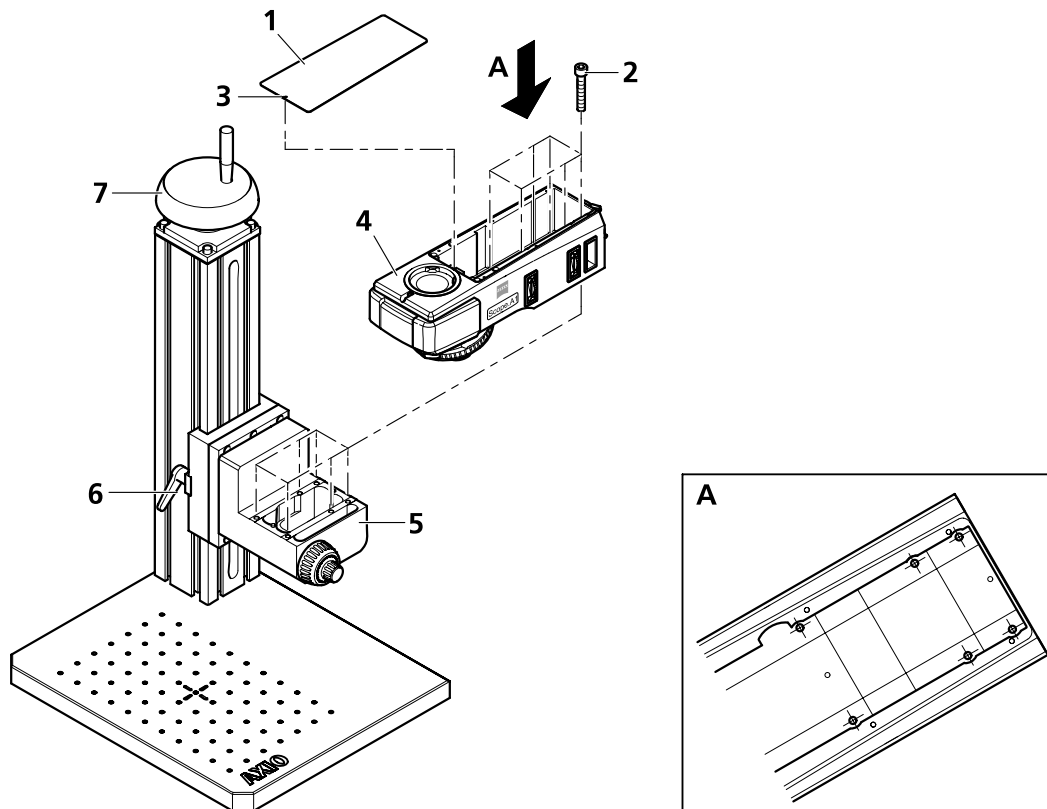

Fig. 3-2 Mounting the upper stand part on the stand column

3.1.3 Mounting the Binocular Tube / Photo Tube

All binocular tubes listed in the systems overview (chapter 2.2) can be mounted on the microscope stand.

- Loosen the hexagon socket screws (Fig. 3-3/3) with the ball head screwdriver SW 3. Remove the dust cover caps (Fig. 3-3/2 and 5) from the bottom of the tube and the dovetail ring socket on the stand.
- Hold the binocular tube (Fig. 3-3/1) or the binocular photo tube at an angle and insert it into the stand socket with the dovetail ring (Fig. 3-3/4). Then push it into a horizontal position. Turn the binocular tube into the desired examination position and tighten the hexagon socket screws with the ball head screw driver.

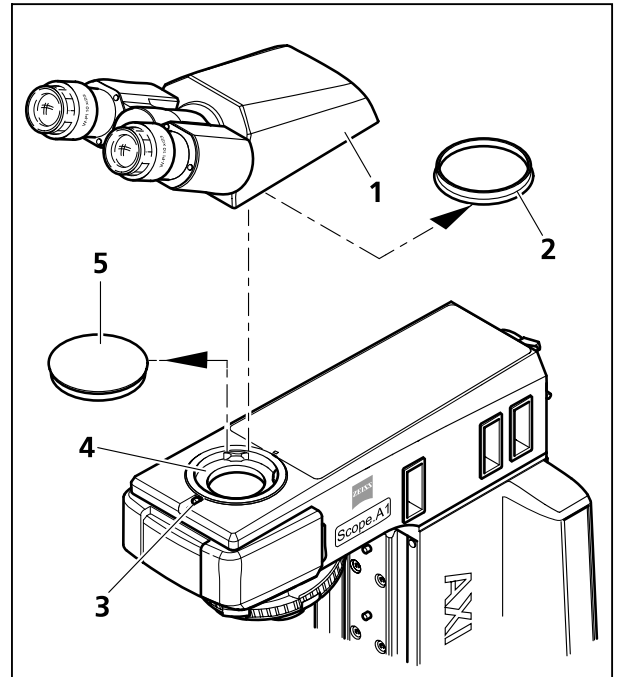

Fig. 3-3 Mounting the binocular tube

3.1.4 Inserting Eyepieces or an Auxiliary Microscope

- Remove both dust cover caps (Fig. 3-4/1 and 4) from the binocular tube.
- Remove both eyepieces (Fig. 3-4/2) from the box and insert them into the binocular tube to the stop.
- Instead of an eyepiece you may insert an auxiliary microscope (Fig. 3-4/3) into one of the binocular nozzles in order to examine aperture, phase and dark field diaphragms and to center phase and dark field diaphragms. These diaphragms can be focused with the adjustable crystalline lens.

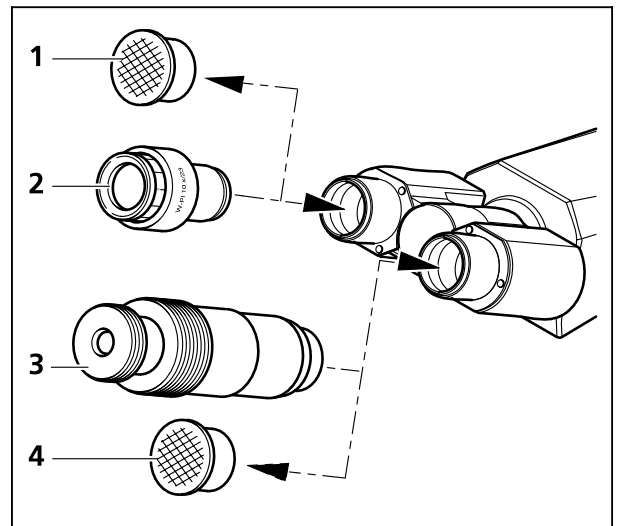

Fig. 3-4 Inserting eyepieces

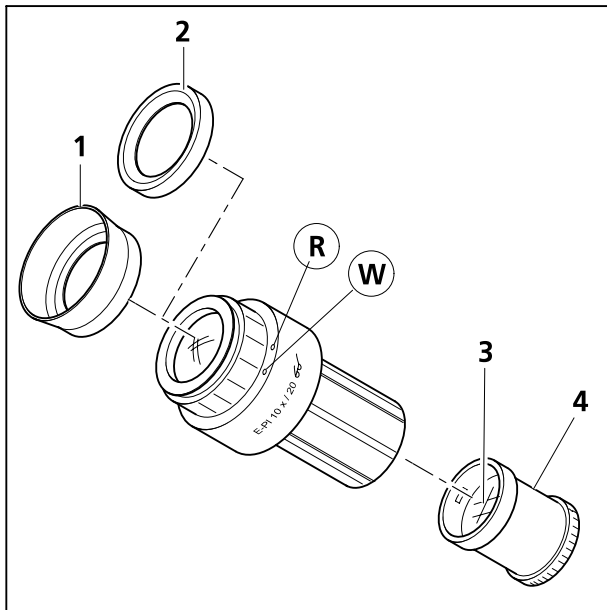

Fig. 3-5 Inserting an eyepiece graticule

How to insert eyepiece graticules

The eyepieces PL 10x/23 Br. foc. are designed to be used with eyepiece graticules.

The slight image shift caused by the added glass is reversed when the zero position is marked by the red dot (Fig. 3-5/**R**) and not the white one (Fig. 3-5/**W**).

The eyepiece graticules (Fig. 3-5/**3**) are glued into screw-in lens parts (Fig. 3-5/**4**) and can thus be changed easily. Complete lens parts with glued-in graticules can be ordered from Zeiss.

How to change a lens part:

- Unscrew the lens part (Fig. 3-5/**4**) with the eyepiece graticule (Fig. 3-5/**3**) and remove it. Then insert the new lens part with the eyepiece graticule.

 If you want to add your own eyepiece graticule to the lens part after removing it, make sure that the writing is face down before screwing the lens part back in.

How to insert eye guards

The eyepieces are furnished with protective rubber rings to protect spectacles from being scratched. These rubber rings can be replaced by eye guards.

- Pull the rubber rings (Fig. 3-5/**2**) from the eyepieces, then insert the eye guards (Fig. 3-5/**1**) instead.

If you find the rubber rings hard to remove from the eyepiece slots, try using a blunt stick to press them out.

3.1.5 Mounting Objectives

- Lower the mechanical stage with the stage carrier to the bottom stop or lower the stage carrier with the dovetail.
- Remove the dust protection caps (Fig. 3-6/2) from the appropriate nosepiece openings.
- Take the objective (Fig. 3-6/3) out of its box and mount it to the nosepiece (Fig. 3-6/1), starting with the smallest zoom factor (set up clockwise).
- Instead of a objective, you may mount an object marker (Fig. 3-6/4) to any position of the nosepiece with the aid of an adapter ring W0,8/M27 (Fig. 3-6/5). Don't forget to recap the object marker when not in use in order to prevent it from drying out.

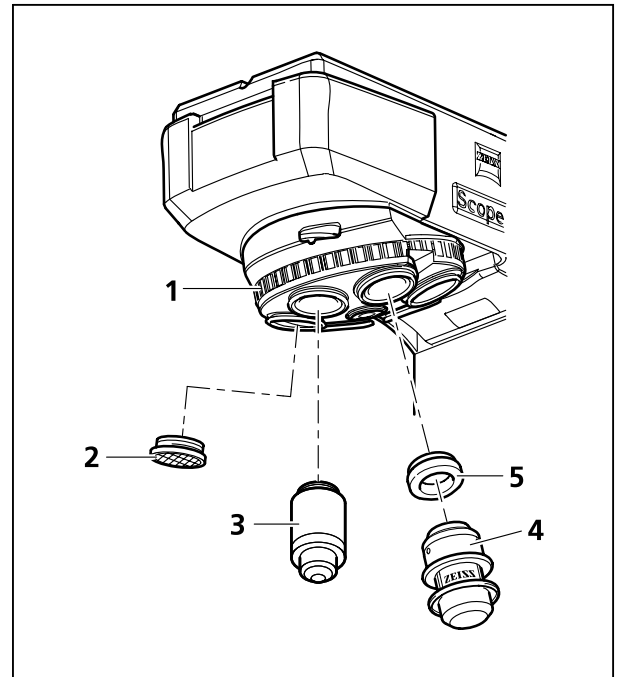



Fig. 3-6 Mounting objectives

 Always place dust covers over the positions in the nosepiece which are presently not being used.

 The adapter ring W0,8/M27 must be used with the objective W0,8.

3.1.6 Installing and Uninstalling "Push&Click" Modules in the Reflector Insert

To install or uninstall the modules, the reflector insert (reflector turret 4- or 6-fold, reflector slider 2-fold) must be removed from the upper stand part.

The reflector turret in the upper stand part FL-LED cannot be removed. Install or uninstall the modules from the front after removing the cover cap.

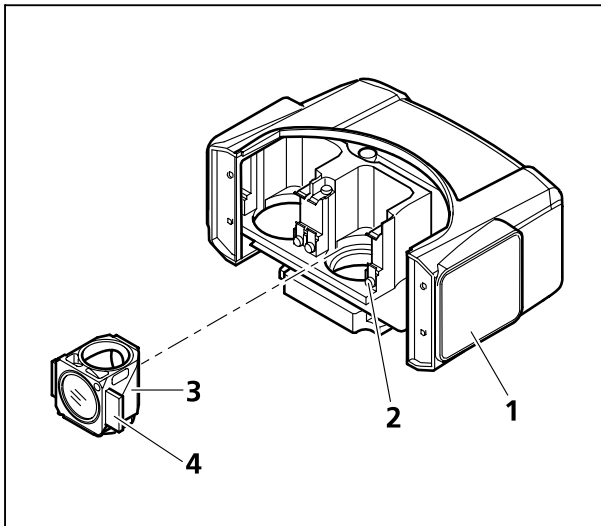

Fig. 3-7 Changing the reflector module in the reflector insert

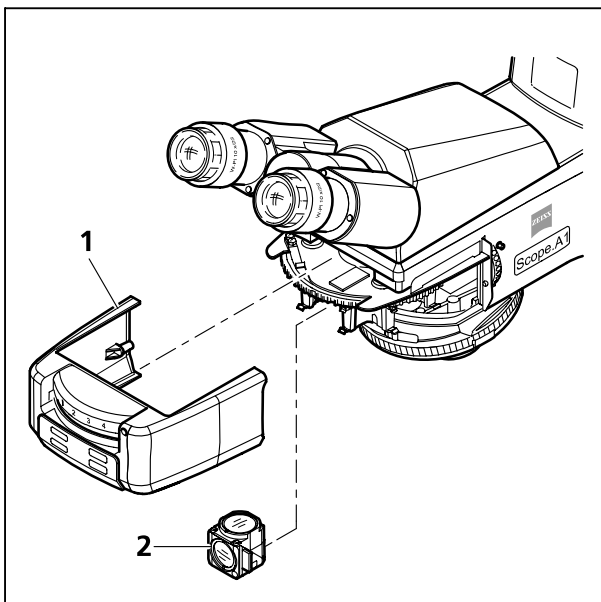

Fig. 3-8 Changing the reflector module in the upper stand part FL-LED

How to install a module:

- Remove the reflector insert (Fig. 3-7/1) from the upper stand part (chapter 3.1.7) and put it aside with the upper side facing down.
- Insert the module (Fig. 3-7/3) (with the upper side facing down) with the aid of its mounting elements on its left and right (Fig. 3-7/4) at a slant from the top into the lower spring clips (Fig. 3-7/2) on the reflector socket.
- Press the module against the upper spring clips of the reflector turret until it engages firmly.



When installing the module into the upper stand part FL-LED, remove the cover cap (Fig. 3-8/1) by pulling it forward, then turn the module (Fig. 3-8/2) by 180° and insert it into the upper spring elements. Engage it firmly by pressing it down.

How to uninstall a module:

- Disengage the module from the upper spring elements by tilting it forward, then lift it off the lower spring elements and remove the module.
- After installing or uninstalling the reflector module, don't forget to replace the reflector insert or the cover cap.

3.1.7 Mounting the Reflector Insert

- First remove the cover cap (Fig. 3-9/1) by inserting the ball head screwdriver (SW 3 mm) into the slit (Fig. 3-9/2). Turn the locking screw counter clockwise to the stop and pull the cover cap forward.
- Put the reflector insert (Fig. 3-9/3) with the reflector modules P&C (e.g. reflector turret 6-fold) into the upper stand part until it stops, hold it and tighten the locking screw again.



When the reflector insert is removed, the reflected light path is automatically blocked so that the glare will not affect the operator.

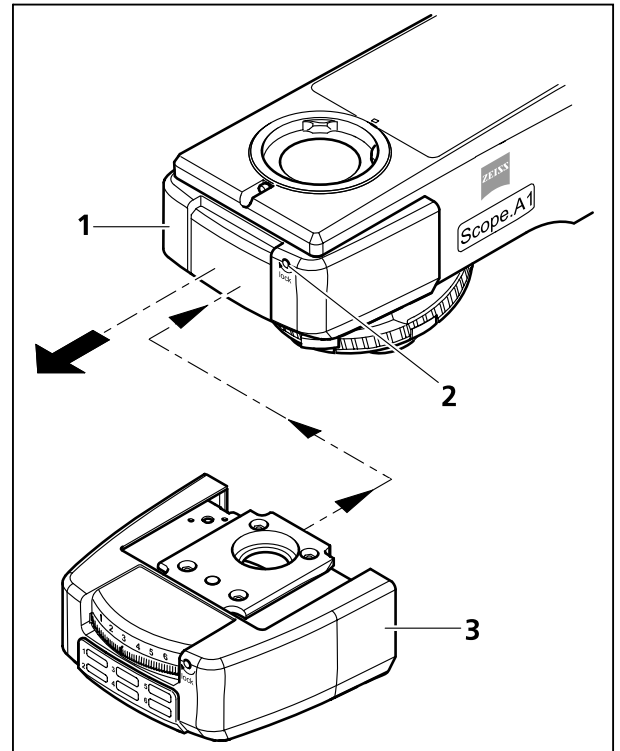

Fig. 3-9 Mounting the reflector insert

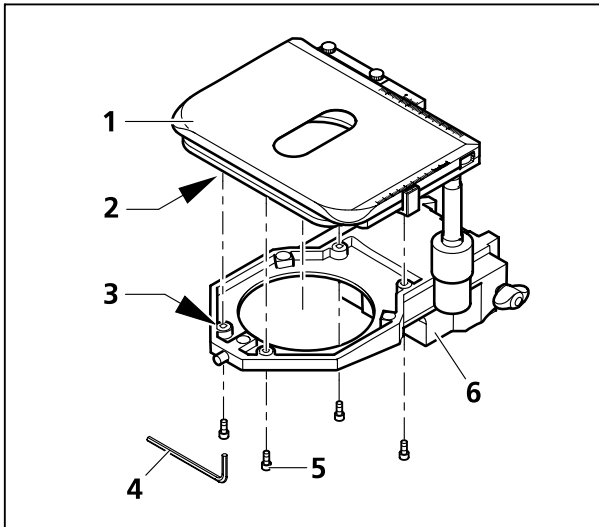

Fig. 3-10 Changing the stable mechanical stage

3.1.8 Mounting the Mechanical Stage

Depending on the type, the mechanical stages can either be stable or they can be rotated and centered. The shift range is 75 mm in X-direction and 50 mm in Y-direction. There are stable stages available with the drive to the right or the left. The rotatable mechanical stage has the drive on its right.

To assemble / disassemble a stage, remove the stage carrier, then mount the stage carrier with the mounted stage onto the stand again.

(1) Stable mechanical stage 75x50 R

a) How to remove the stage

- Remove the four mounting screws (Fig. 3-10/5) on the stage carrier (Fig. 3-10/6) with the aid of the ball head screwdriver SW 3 (Fig. 3-10/4).
- Pull off the stage (Fig. 3-10/1) from the stage carrier. This is easier if you turn the stage and its carrier over.

b) How to mount the stage

- Put the stage (Fig. 3-10/1) onto the stage carrier (Fig. 3-10/6) so that the threaded holes in the bottom of the stage (Fig. 3-10/2) are on top of the corresponding holes in the stage carrier (Fig. 3-10/3).
- Insert the four mounting screws (Fig. 3-10/5) from below through the holes in the stage carrier and screw them into the bottom of the stage.
- Align the stage in the XY-direction before tightening the screws.

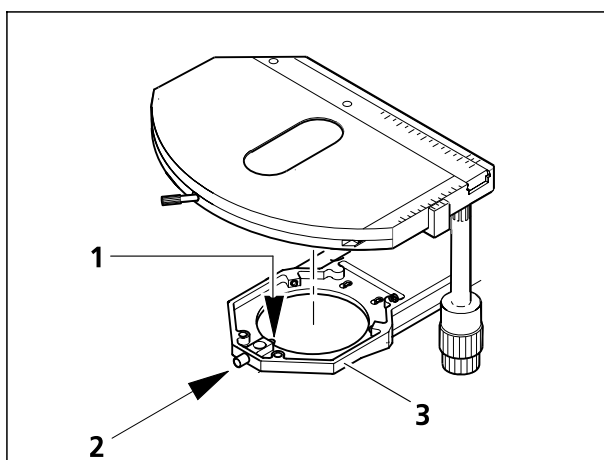



Fig. 3-11 Changing the rotatable mechanical stage

(2) Rotatable mechanical stage 75x50/240° R

 Rotatable stages can only be used together with the stage carrier for rotatable stages (430710-9010-000).

a) How to remove the stage

- Loosen the screw caps (Fig. 3-11/2) of the spring box with approx. 3 turns.
- Press the stage forward against the spring pin (Fig. 3-11/1), lift the backside off the stage carrier (Fig. 3-11/3) and remove it by lifting it upward.
- Tighten the screw caps (Fig. 3-11/2).

b) How to mount the stage

- Loosen the screw caps (Fig. 3-11/2) of the spring box with approx. 3 turns.
- Put the stage with the dovetail ring notch onto the spring pin (Fig. 3-11/1).
- Press the stage forward against the spring pin and lower its back into the stage carrier (Fig. 3-11/3).
- Tighten the screw caps (Fig. 3-11/2).

c) How to center the stage

When using objectives with a high magnification, only one chosen objective can be centered exactly at a time.

All stages are delivered precentered, i.e. when the stage is turned, the detail of the object in the focus remains in the center of the image. If the detail shifts out of the center when the stage is turned (Fig. 3-12/5), then it becomes necessary to recenter the stage.

- Loosen the clamping screws of the stage (Fig. 3-12/4) and the screw caps of the stage carriers (Fig. 3-12/1).
- Determine the maximal shift of the object (Fig. 3-12/5, arrow point) to the cross line in the eyepiece by turning the stage.
- Shift the object detail towards the center of the cross line by turning the two centering screws on the stage carrier (Fig. 3-12/2) each with an hexagon head screwdriver SW 1.5 (Fig. 3-12/3) half the length of the arrow. Repeat the procedure if the object detail shifts out of the center again when turning the stage.
- After finishing the centering procedure tighten the screw caps (Fig. 3-12/1) again.

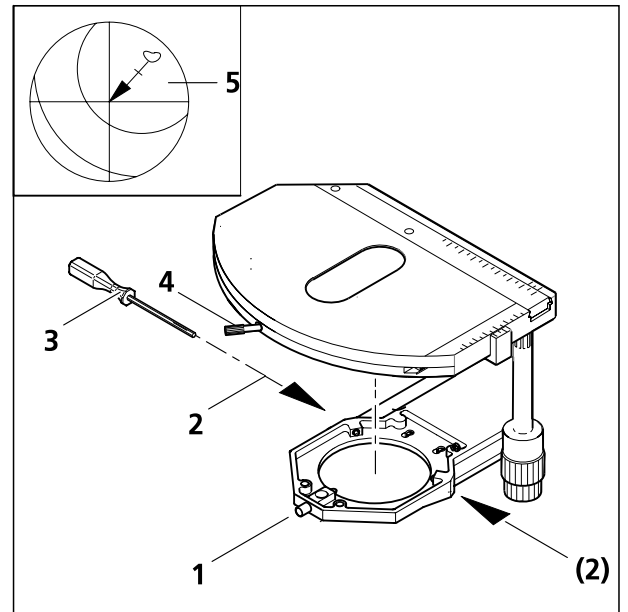

Fig. 3-12 Centering the rotatable mechanical stage

The stage can be turned by 240° within a shifting range of $y \leq 27$ mm. No turning of the stage is possible outside of this range.

(3) Adjusting the drive length on the ergonomics

An axial shift of the gear knobs by a **maximum of 15 mm** can enhance the drive length of the **X** and **Y** shift on the mechanical stages with ergonomic drive.

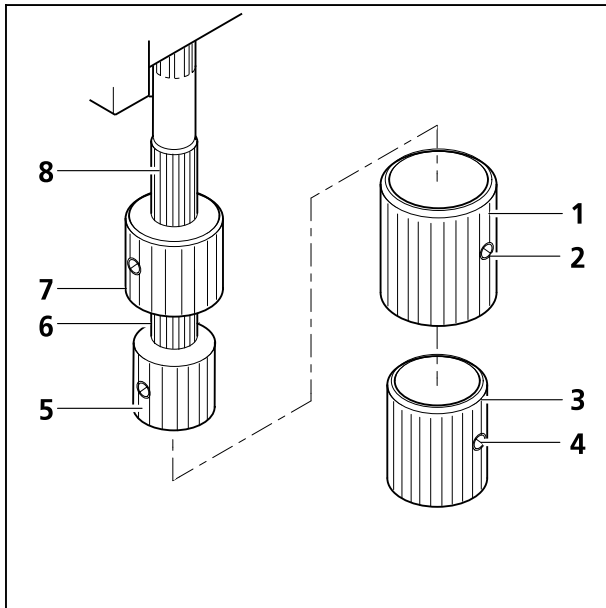

Fig. 3-13 Adjusting ergonomic drive

(4) Removing and mounting the additional sleeves

Both gear knobs for the stages with the order no. 432035-9030-000, 432035-9040-000 and 432035-9050-000 are equipped with additional sleeves for an even more sensitive adjustment of the object position. These sleeves can be removed in those cases when it is important to shift the object more quickly.

- Loosen both clamping screws (Fig. 3-13/4) on the lower additional sleeve (Fig. 3-13/3) and remove them by pulling them down. Then loosen both clamping screws (Fig. 3-13/2) on the upper additional sleeves (Fig. 3-13/1) and remove them by pulling them down as well.
- Mount the additional sleeves again on the gear knobs by proceeding in the reverse order. Tighten the clamping screws when you are done.

(5) Adjusting the friction (smoothness of operation) on both gear knobs of the ergonomics

The smoothness of ergonomics operation is factory-adjusted to a mid degree. The operator can change the friction as follows:

a) How to adjust the X-direction

- Remove the additional sleeves (Fig. 3-13/1 and 3) from the gear knobs by loosening the clamping screws.
- Shift the X-gear knob (Fig. 3-13/5) downward and the Y-gear knob (Fig. 3-13/7) upward.
- Hold the X-gear knob (Fig. 3-13/5) and turn the light colored knurled ring above it (Fig. 3-13/6) to the right (increased smoothness) or left (decreased smoothness) until you reach the desired degree.

b) How to adjust the Y-direction

- Hold the Y-gear knob (Fig. 3-13/7) and turn the light colored knurled sleeve above it (Fig. 3-13/8) to the right (increased smoothness) or the left (decreased smoothness) until you reach the desired degree.
- Replace the additional sleeves and tighten the clamping screws.

 Enhance the life span of the stage by regularly removing the particles abraded from the object carriers. Avoid getting any particles in the mechanical guiding system of the X-adjustment.

3.1.9 Mechanical Stages with Friction Adjustment

Drive length and friction for the X- and Y-adjustment can be adjusted individually on the standard mechanical stage (432035-9000-000) and the mechanical stage 432035-9070-000.

(1) Adjusting the drive length on the stage drive

The drive length of the X- and Y-drive can be adjusted by an axial shift of the gear knob (Fig. 3-14/4 and 1) within a range of approx. 15 mm.

(2) Adjusting the frictional momentum of the gear knobs for the X-/Y-adjustment of the mechanical stage

The friction momentum of the gear knobs is factory-adjusted to a mid degree which can be changed as follows if necessary:

a) X-drive

- Slide the gear knob for the X-adjustment (Fig. 3-14/4) all the way down.
- Take the enclosed adjustment pin (Fig. 3-14/5) out of the gear knob for the Y-adjustment (Fig. 3-14/1) and stick it into one of the holes on the lower hole nut (Fig. 3-14/3).
- Hold the gear knob for the X- adjustment (Fig. 3-14/4) and turn the hole nut with the adjustment pin clockwise (smaller friction momentum: **-**) or counter clockwise (larger friction momentum: **+**) until you reach the desired friction degree (see Fig. 3-14).
- The adjustment should not be more than **one** rotation.

b) Y-drive

- Slide the gear knob for the Y-adjustment (Fig. 3-14/1) all the way up.
- Stick the enclosed adjustment pin (Fig. 3-14/5) into the hole on the upper hole nut (Fig. 3-14/2).
- Hold the gear knob for the Y-adjustment (Fig. 3-14/1) and turn the hole nut with the adjustment pin clockwise (smaller friction momentum: **-**) or counter clockwise (larger friction momentum: **+**) until you reach the desired friction degree.
- The adjustment should not be more than **one** rotation.
- Replace the adjustment pin in the gear knob for the Y-adjustment (Fig. 3-14/1).

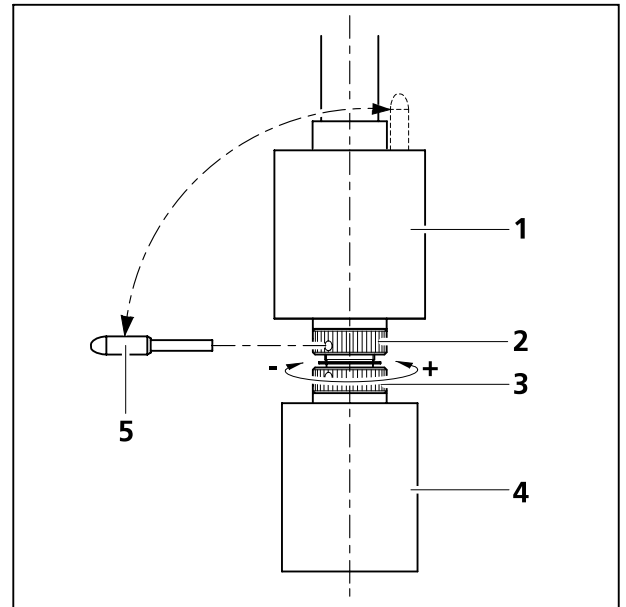

Fig. 3-14 Adjusting the frictional momentum

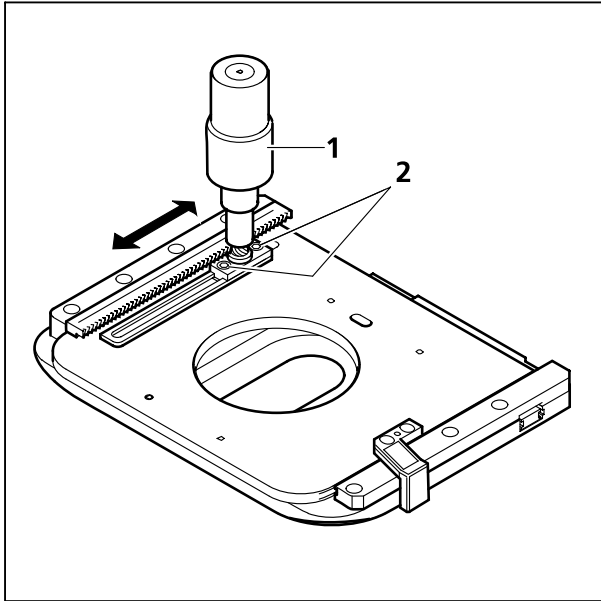

Fig. 3-15 Adjusting the connecting rod position for the ergo drive

(3) Adjusting the connecting rod position of the ergo drive

The connecting rod position on the ergo drive of the mechanical stage 75x50 R (432035-9010) can be adjusted individually.

- Remove the stage with the stage carrier from the stand (see chapter 3.1.13) and put it aside face down.
- Loosen both clamping screws (Fig. 3-15/2) on the connecting rod (Fig. 3-15/1).
- Slide the connecting rod (Fig. 3-15/1) in the groove into the desired position.
- Tighten both clamping screws (Fig. 3-15/2).
- Mount the stage carrier with the stage on the lower stand part (see chapter 3.1.13).

3.1.10 Mounting the LED Illuminator for Transmitted Light



BE CAREFUL, LED radiation!

LED class 2M, do not look into the beam!



The LED illuminator can only be inserted on the lower stand part for LED illumination.

- If the condenser carrier is already mounted, remove the stage carrier from the stand (see chapter 3.1.13).
- Screw the bolt (Fig. 3-16/2) by hand into the threaded holes on the bottom of the condenser carrier (Fig. 3-16/6 and 7).
- Hold the LED illuminator (Fig. 3-16/5) parallel to the bottom of the condenser carrier (Fig. 3-16/1), pin it upward onto the bolts (Fig. 3-16/2) and lock it with the screws (Fig. 3-16/4) on the left side of the LED illuminator.
- Slide the slider with the diffusion disk (Fig. 3-16/3) into the LED illuminator or, for transmitted light polarization contrast, slide in the polarizer for LED (427708-0000-000).
- Unscrew three screws (Fig. 3-17/1) of the cover (Fig. 3-17/2) of the foot and remove the cover.
- Plug the LED illuminator into the port on the cover (Fig. 3-17/3).
- Place the cover on the foot, thread the cord through the hole in the cover and tighten the three screws.
- Mount the stage carrier (see chapter 3.1.13).

The intensity of the LED reflected light can be controlled with the control wheel (operable from both sides) (Fig. 3-17/4).

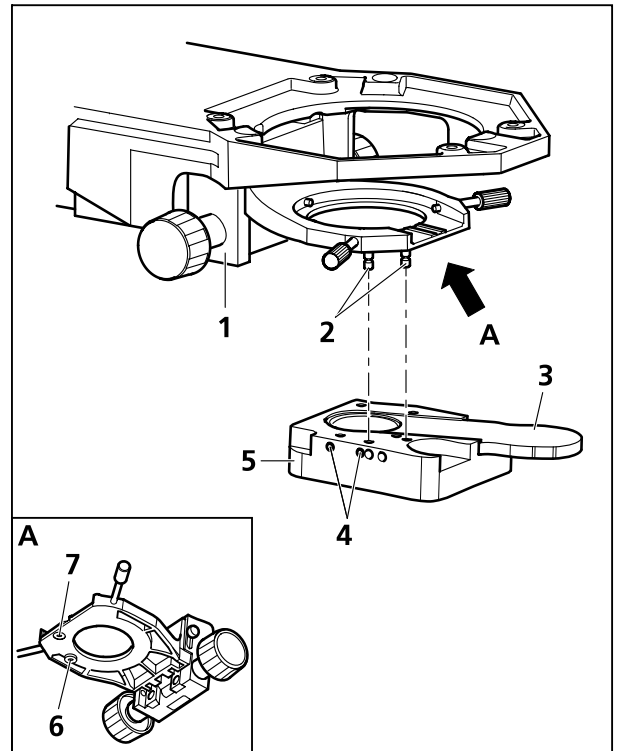

Fig. 3-16 Mounting the LED illuminator on the condenser

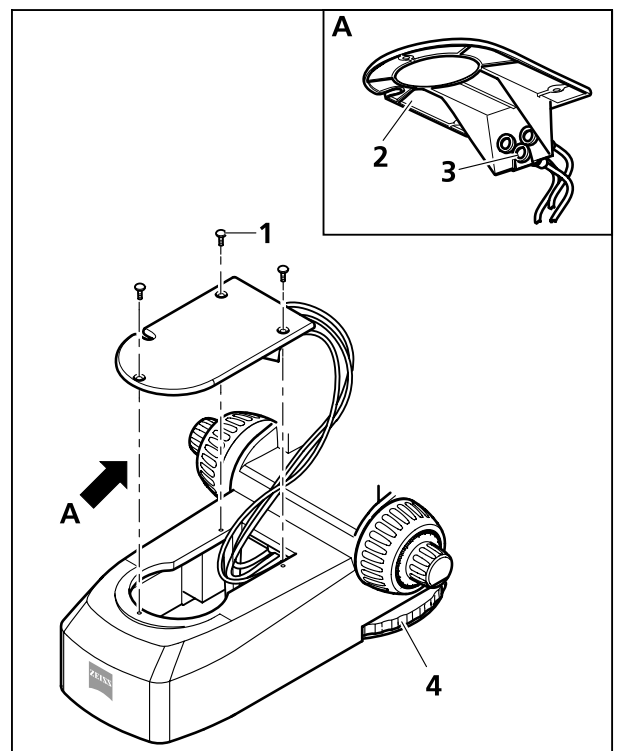

Fig. 3-17 Connecting the LED illuminator



Guidelines for the use of the LED illuminator accessories:

The slider with diffusion disk 10° emits more light for examining objects with the eyepieces.

The slider with diffusion disk 80° emits a more homogeneous light for examining objects with the camera.

The slider handle may serve as a manual shutter in order to block out the disturbing self-fluorescence in the fluorescence light.

You may adjust the color temperature for examining objects by inserting color temperature filters into the slider with diffusion disk (retainer with prescrew ring).

Yellow filter 1 --> changes the color temperature of the LED (about 7500 K) to about 4500 K

Yellow filter 2 --> to about 5500 K

Yellow filter 3 --> to about 4000 K

Polarizer LED is a special slider which can be ordered for simple DL polarization procedures.

A simple polarization contrast is possible with the polarizer, yet no conoscopy can be performed.

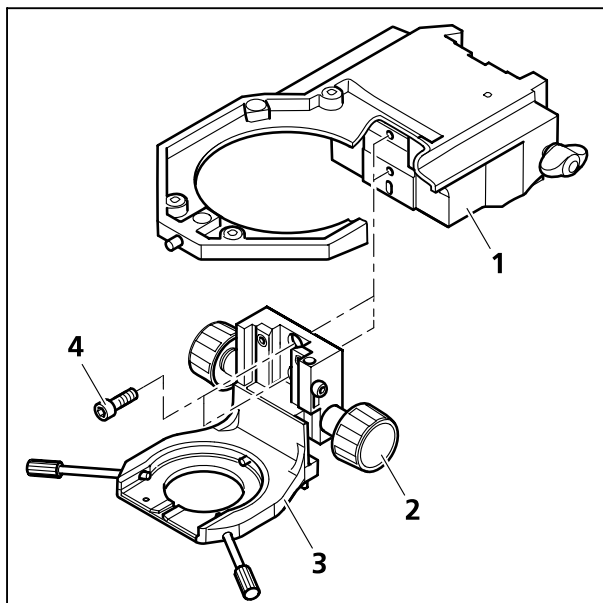

Fig. 3-18 Mounting the condenser carrier

3.1.11 Mounting the Condenser Carrier

- Adjust the guide of the condenser carrier (Fig. 3-18/3) with the gear knob (Fig. 3-18/2) until both screws (Fig. 3-18/4) become accessible.
- Mount the condenser carrier on the stage carrier (Fig. 3-18/1), slide it firmly and straight up to the upper stop and tighten both screws.

3.1.12 Mounting the Condenser

- Slide the stage carrier with the focusing drive to the upper stop.
- Open the frontal optic (if switchable) on the condenser with the lever (Fig. 3-19/7). Unscrew both centering screws (Fig. 3-19/5) on the condenser carrier until you cannot see the end parts anymore.
- Slide the condenser carrier (Fig. 3-19/3) with the gear knob for vertical adjustment (Fig. 3-19/2) all the way down.
- Insert the condenser (Fig. 3-19/8) between the condenser carrier (Fig. 3-19/3) and the stage carrier (Fig. 3-19/1). Adjust the pin screw on the bottom of the condenser in direction of the slot (Fig. 3-19/6).
- Press the condenser with the dovetail ring against the spring box (Fig. 3-19/4) of the condenser carrier until the condenser can be placed on the condenser carrier horizontally.
- Release the condenser and its pin screw will slide into the front slot (Fig. 3-19/6).
- Tighten the centering screws until they engage in the condenser's dovetail ring.



Proceed accordingly when mounting other condensers.

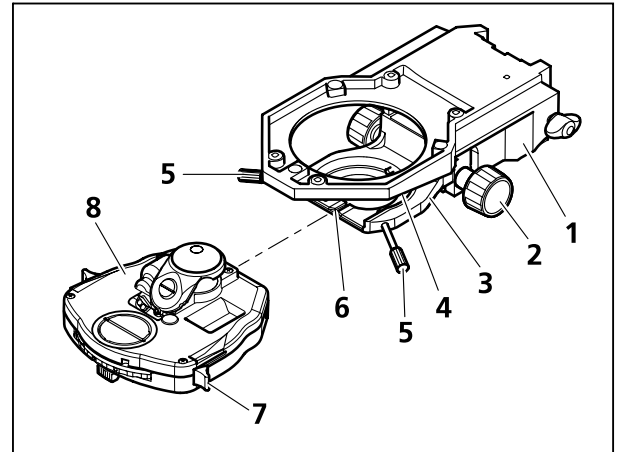

Fig. 3-19 Mounting the condenser

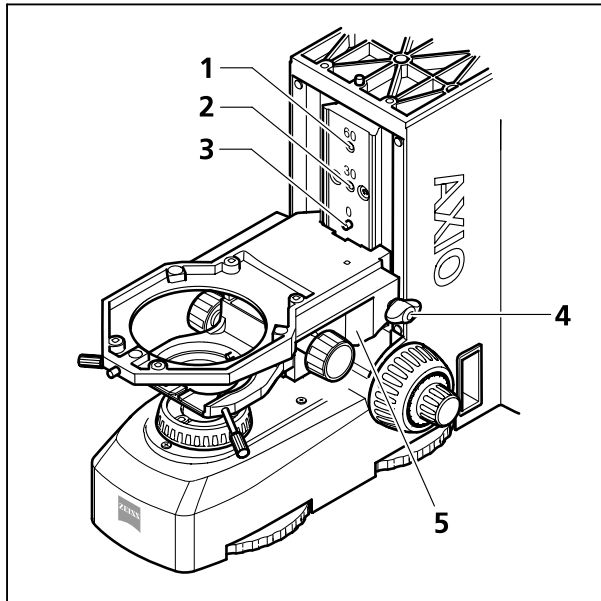

Fig. 3-20 Mounting the stage carrier

3.1.13 Mounting the Stage Carrier

- Screw the shoulder screw (Fig. 3-20/3) into the appropriate opening:
 - Opening with mark **0**: **no** adapter is mounted for specimen holder expansion (Fig. 3-20/3),
 - Opening with mark **30**: adapter is mounted for expanding specimen holder by **30 mm** (Fig. 3-20/2),
 - Opening with mark **60**: adapter is mounted for expanding specimen holder by **60 mm** (Fig. 3-20/1).
- Insert the stage carrier (Fig. 3-20/5) at a slight angle (beneath the shoulder screw) first left into the guide, then press it in straight and tighten the Tommy screw (Fig. 3-20/4) slightly.
- Push the stage carrier along the guide upward until it engages in the shoulder screw. Tighten the Tommy screw.
- Check for an exact position of the guide.

3.1.14 Inserting the Halogen Lamp 12 V, 50 W

- Switch off the microscope and pull its plug. Wait at least 15 min for the halogen lamp to cool down.
- Remove the halogen lamp HAL 50 (Fig. 3-21/3) from the back of the stand (Fig. 3-21/2) and put it down with the open side facing up.
- Remove a used halogen lamp 12 V, 50 W (if necessary) by pulling it out of the cap (Fig. 3-22/2) in an upward motion.
- Press the new lamp (Fig. 3-22/1) with its two cap pins delicately and carefully into the lamp cap (Fig. 3-22/2). Be careful not to touch the protective glass of the lamp. The lamp mustn't be canted in order to avoid bending its cap pins or damaging the lamp holder.
- Place the halogen lamp HAL 50 with the connecting pins into the back side of the microscope and press until the lamp engages securely.
- Replace the plug of the microscope.

The intensity can be controlled with the control wheel (Fig. 3-21/1).

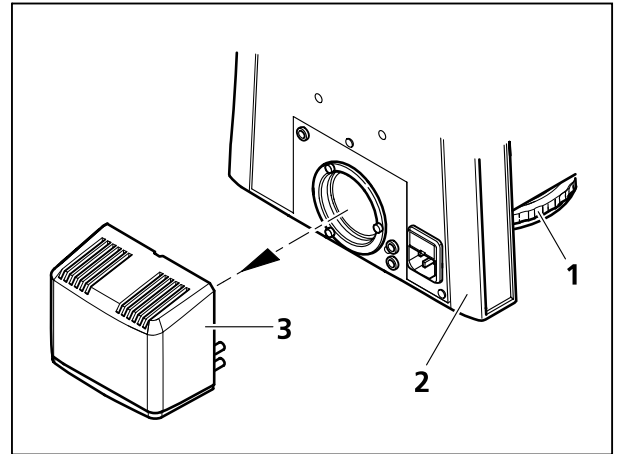

Fig. 3-21 Removing a halogen lamp HAL 50

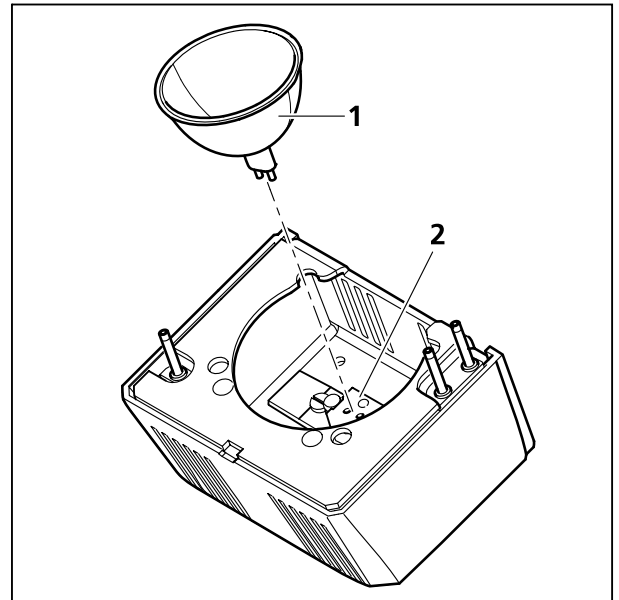

Fig. 3-22 Inserting a halogen lamp 12 V, 50 W

3.1.15 Halogen Lamp HAL 100

The halogen lamp HAL 100 may serve as light source for transmitted light and reflected light procedures (except fluorescence light) as long as either the lower stand part or the upper stand part are equipped with the appropriate connection piece. When mounting the halogen lamp, no difference is made between reflected light and transmitted light procedures.

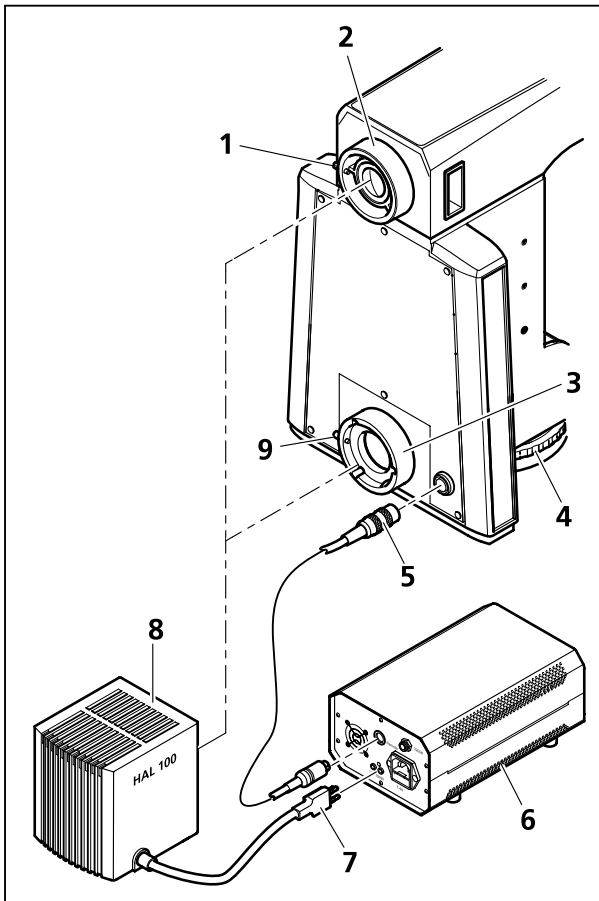

Fig. 3-23 Mounting the halogen lamp HAL 100

3.1.15.1 Mounting the halogen lamp HAL 100



Before you switch on the halogen lamp, please be sure to remove the tools which are included in the lamp case. The lamp generates a lot of heat which could damage these tools (see chapter 3.1.15.3).

- Remove the cap from the reflected light or transmitted light connector.
- Insert the lamp case (Fig. 3-23/8) with the dovetail ring into the connector (Fig. 3-23/2 and Fig. 3-23/3). Now fixate it by tightening the clamping screw (Fig. 3-23/1 or Fig. 3-23/9) with the ball head screwdriver SW 3.



Due to the lack of ground clearance it is important to avoid canting the lamp when inserting it into the lower stand part. Check for straight and correct fit.

- Insert the 3-pin lamp plug (Fig. 3-23/7) into the back of the external power supply (Fig. 3-23/6).

 When mounting HAL 100 to the lower stand part for HAL 100 illumination, it is necessary to use an additional control cord (Fig. 3-23/5) for the light intensity (see chapter 3.2.2). The light intensity of HAL 100 can then be adjusted with the control wheel (Fig. 3-23/4).

 The light intensity of HAL 100 can also be adjusted with the external power supply unit. In this case, the control cord needs to be removed.

3.1.15.2 Adjusting the halogen lamp HAL 100

Rough setting

- After loosening the clamping screw (Fig. 3-23/1 or Fig. 3-23/7), remove the ready-to-operate halogen lamp (Fig. 3-24/2) from the microscope stand.
- Switch on the auxiliary power supply unit of the halogen lamp HAL 100 (see chapter 3.3).
- Direct the light beam towards a projecting surface (wall) which is at least 3 m away.



Never look directly into the light emitting aperture of the lamp!

- Adjust the adjustment screw (Fig. 3-24/3) with a ball head screwdriver SW 3 until both images of the lamp filament appear as sharp as possible on the projection surface.
- Adjust the adjustment screws (Fig. 3-24/4 and 5) so that the lamp filament of one image exactly fills the gaps of the reflected image (Fig. 3-24/1).

Fine setting

- Mount the microscope lamp on the microscope stand again and tighten the clamping screw to lock it.
- If applicable, turn off the diffusion disk transmitted light and remove the filter from the beam path.
- Focus the objective $\leq 40\times$ on the sample and go to a free place of the object.
- Remove the eyepiece and center the lamp filament and its reflection in the eye pupil image with the adjustment screws (Fig. 3-24/4 and 5).
- Optimize the even illumination of the pupil image with the adjustment screws (Fig. 3-24/3).
- Switch on the diffusion disk and replace the filter wheels.

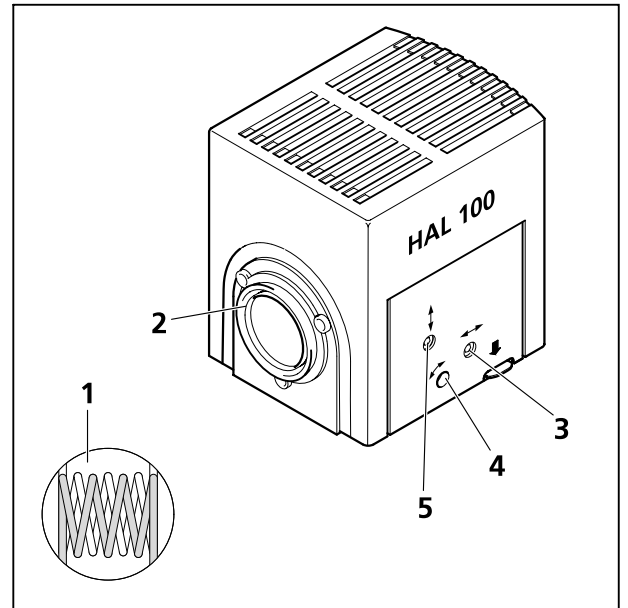

Fig. 3-24 Adjusting a halogen lamp HAL 100

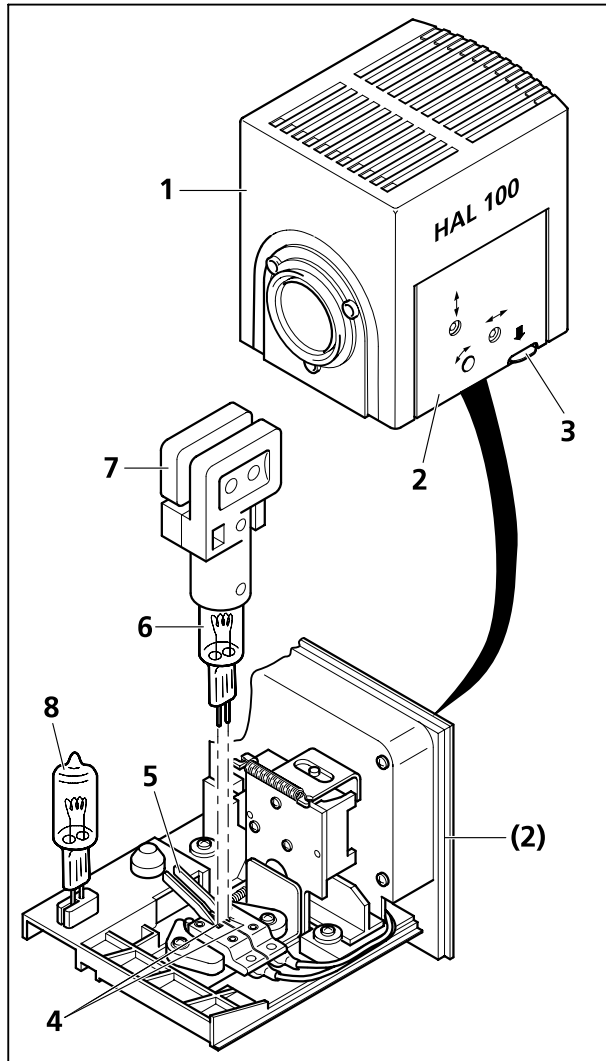

Fig. 3-25 Changing a halogen lamp

3.1.15.3 Changing the halogen lamp 12 V, 100 W



CAUTION
Hot surface!



DANGER OF BURNS!
Always let the lamp case cool off for at least 15 min.!



It is not necessary to remove the lamp case from the stand when replacing the halogen lamp. Do **not** store the included tools for the halogen lamp (Fig. 3-25/7) in the lamp case when the halogen lamp is in operation. The replacement lamp (Fig. 3-25/8) can remain in the lamp case.

- Switch off the auxiliary power supply unit of the HAL 100 (see chapter 3.2.3). Remove 3-pin plug of the HAL 100.
- Press down the release button (Fig. 3-25/3) of halogen lamp HAL 100 (Fig. 3-25/1). Pull the lamp carrier (Fig. 3-25/2) out completely and put it aside.
- Press down both spring levers (Fig. 3-25/5) and pull out the old halogen lamp (Fig. 3-25/6) in an upward motion.
- Press down both spring levers, insert the new lamp into the lamp cap (Fig. 3-25/4) and release the spring levers. Use only the included special tools (Fig. 3-25/7) when holding/grabbing the halogen lamp. Traces of skin grease on the halogen lamp can impair its life span.
- Press the spring levers down again briefly. The lamp is now centered.
- Replace the lamp carrier and slide it in until it engages fully.
- Replug the 3-pin plug of HAL 100.

3.1.16 Inserting the Adjustment Aid into the Upper Stand Part FL/HBO

- Remove the cover (Fig. 3-26/1) from the mounting aperture of the adjustment aid.
- Insert the adjustment aid (Fig. 3-26/4) and tighten the three included screws (Fig. 3-26/3).
- Mount the cap with the opening (Fig. 3-26/2). Make sure it locks.
- Slide in the movable connecting piece of the adjustment aid.

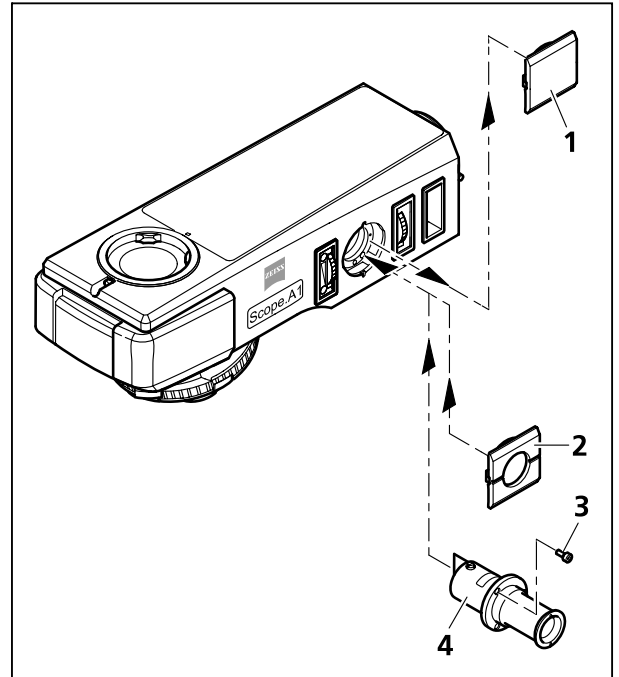

Fig. 3-26 Inserting the adjustment aid

3.1.17 HBO 50 Illuminator

3.1.17.1 Inserting or changing the burner of the HBO 50 illuminator



BE CAREFUL – Danger of burns! Before changing the burner of HBO 50 switch off the transformer and pull its plug. Let the lamp case cool off for at least 15 min. After the lamp case has cooled down, remove the HBO 50 from the upper stand part and put it aside on a plane surface.

- Loosen the clamping screw (Fig. 3-27/1) with the ball head screwdriver SW 3.
- Press down the release button (Fig. 3-27/2) of the HBO 50, pull out the lamp carrier (Fig. 3-27/3) and set it aside.

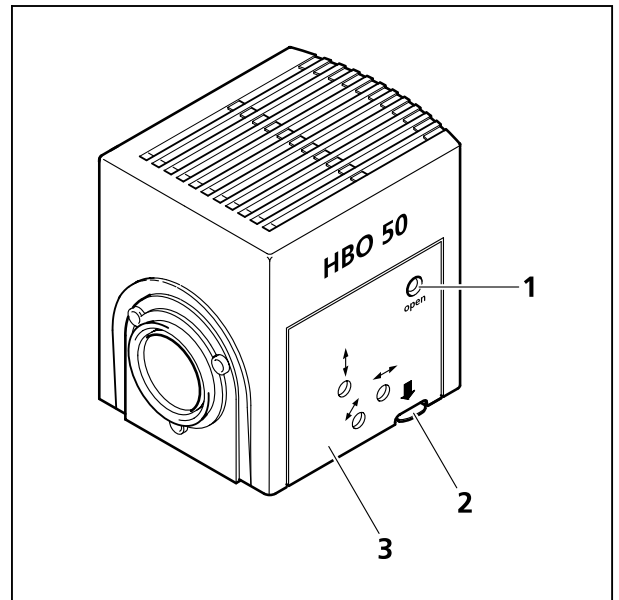

Fig. 3-27 Opening the HBO 50

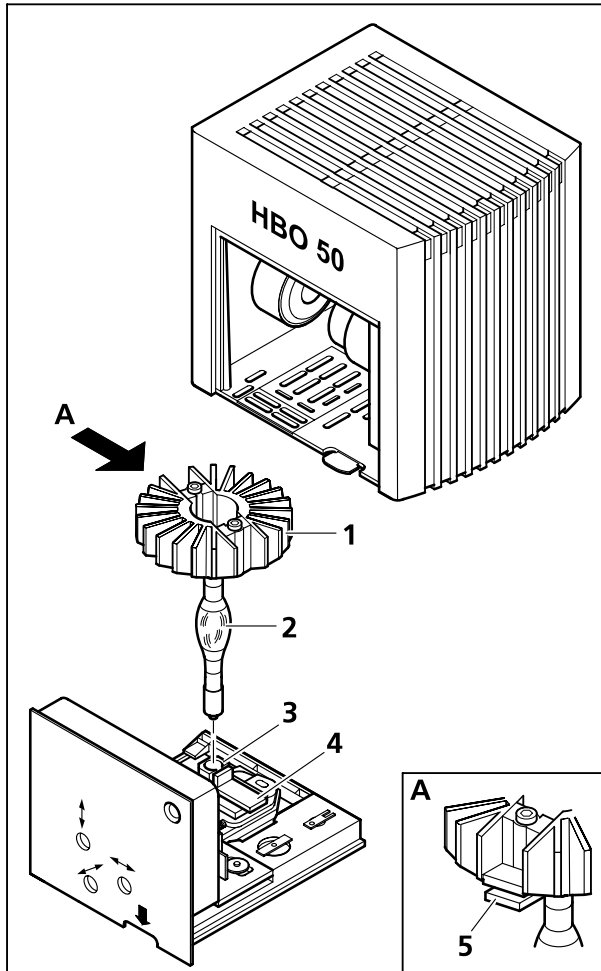

Fig. 3-28 Changing the burner

- Press the spring lever (Fig. 3-28/5) on the heatsink up and pull the heatsink (Fig. 3-28/1) off the inserted dummy or the used burner (Fig. 3-28/2). Lay it aside carefully.



The cord on the heatsink must not be removed or damaged.

- Press down the spring lever (Fig. 3-28/4) on the lower lamp socket and pull the dummy / burner (Fig. 3-28/2) out of the socket (Fig. 3-28/3) in an upward motion. Release the spring lever.



Dispose of the used burners according to legal regulations. Follow the manufacturer's guidelines!

- Press the spring lever (Fig. 3-28/4) on the lower lamp socket down again and insert the burner into the socket (Fig. 3-28/3). Do not touch the burner's glass bulb. Release the spring lever.



Avoid getting fingerprints on the burner's glass parts. Remove immediately if fingerprints occur.

- Press spring lever (Fig. 3-28/5) on the heatsink up and mount heatsink to the burner.
- Insert lamp carrier into lamp case and slide until it engages. Tighten the clamping screw (Fig. 3-27/1).
- Write down the readings of the operation hour's meter (transformer). After 100 operation hours the burner must be replaced.

3.1.17.2 Mounting HBO 50 illuminator

- Mount HBO 50 illuminator (Fig. 3-29/3) on the connection piece (Fig. 3-29/1) of the upper stand part, align it and tighten the clamping screw (Fig. 3-29/2).
- Plug the HBO 50 connection cord into the transformer. Then plug the transformer into an electrical outlet.
- Switch the HBO 50 illuminator on and off by pressing the power switch on the front of the power supply unit. The lamp ignites automatically when switched on.

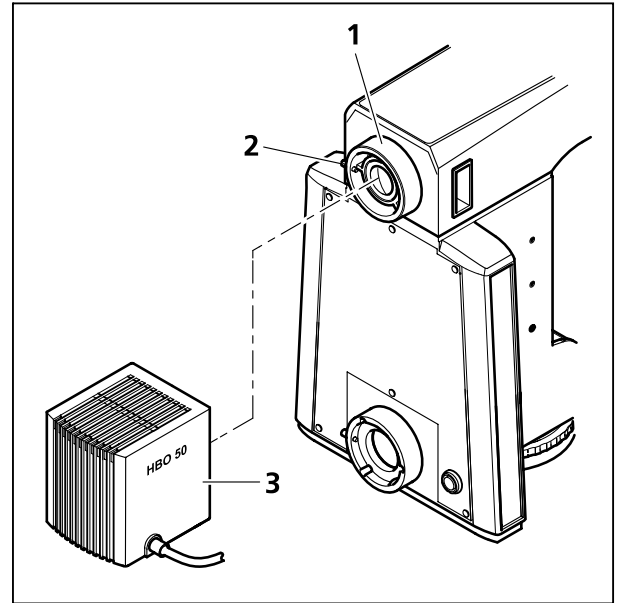

Fig. 3-29 Mounting the HBO 50

3.1.17.3 Adjusting the HBO 50 illuminator

If the Axio Scope.A1 is equipped with an adjustment aid (to be ordered separately), the HBO 50 can remain on the fluorescence reflected light illuminator when adjusting the burner.

- Switch on the illuminator after mounting it fully on the transformer. The burner ignites automatically.



If the images of the light arc and the reflection overlap, the burner's thermal load can increase. This may shorten its lifespan.

- Make sure that the FL attenuator is set to 100 % transmission.
- Pull out the adjustment aid (Fig. 3-30/4). The adjusting aid's display panel (Fig. 3-30/5) shows the burner's light arc (in a lighter color) and its reflection (slightly darker).
- With the aid of the adjustment screw (Fig. 3-30/1) adjust the burner axially to the mirror so that both light arcs appear the same size in the display panel of the adjustment aid (see Fig. 3-30/5).

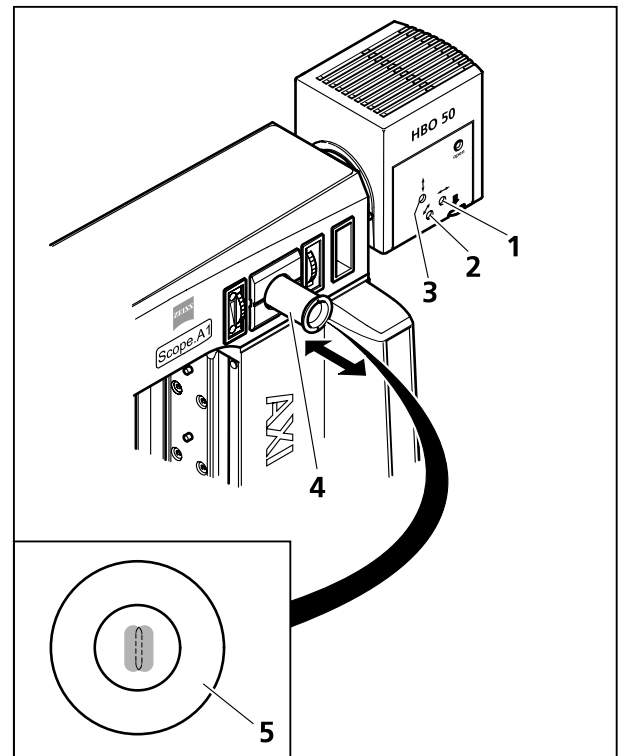

Fig. 3-30 Adjusting the HBO 50

- With the aid of the adjustment screws center the light arc and its reflection vertically (Fig. 3-30/3) and horizontally (Fig. 3-30/2) and position those in a parallel line within the adjustment circle of the display panel (Fig. 3-30/5). Light arc and reflection should not overlap.
- Slide the adjustment aid back in after finishing the adjustment procedure.

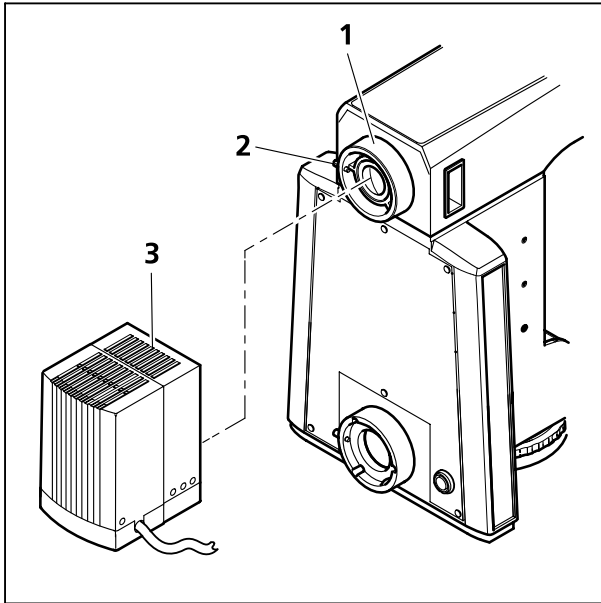

Fig. 3-31 Mounting the HBO 100

3.1.18 HBO 100 Illuminator

3.1.18.1 Inserting the mercury vapor short arc lamp HBO 103 W/2

For safety reasons, the illuminator HBO 100 and the mercury vapor short arc lamp HBO 103 W/2 are packed separately.

The first step in order to put the lamp HBO 103 W/2 in operation is to insert it in the lamp house.

Please read the manual included with the unit before inserting or replacing the lamp HBO 103 W/2.



CAUTION

Please use a FL attenuator (if it is not installed permanently) in order to change the transmission. Grey filters are not resistant enough on the long run.

3.1.18.2 Mounting the HBO 100 illuminator

- Remove the cover from the reflected light connection piece (Fig. 3-31/1).
- Insert the lamp case (Fig. 3-31/3) with the dovetail ring into the reflected light connection piece (Fig. 3-31/1) on the back of the unit. Tighten the clamping screw (Fig. 3-31/2) with the ball head screwdriver SW 3.
- Connect the multi-pole HBO 100 lamp plug with the adapter (Fig. 3-32/1) of transformer HBO 100 W. Secure with a retaining ring.
- First plug the cord into the outlet (Fig. 3-32/2) of transformer HBO 100 W, then insert the power plug into the electrical outlet.

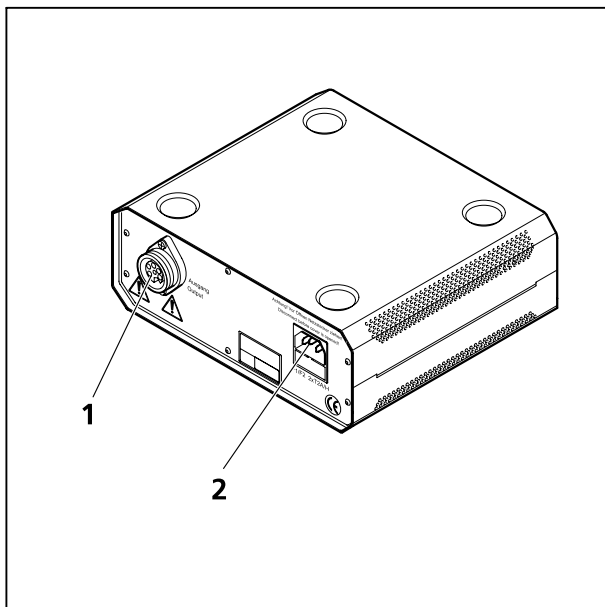



Fig. 3-32 Transformer HBO 100 W

3.1.18.3 Adjusting the HBO 100 illuminator

The HBO 100 illuminator is available in two variants (manual and automatic adjustment).

The self-adjusting HBO 100 (423011-9901-000) adjusts automatically when the transformer is turned on.

Here is how to adjust the HBO 100 illuminator with manual adjustment (423010-0000-000).

 If the FL attenuator is in the reflected light beam path, make sure that it is adjusted to 100 % transmission.

- Turn on HBO 100 illuminator (Fig. 3-34/1) on the transformer HBO 100 W (Fig. 3-38/1) and wait until it reaches its operational temperature.
- Pull adjustment aid (Fig. 3-33/1) out of the microscope stand. The lighter colored focal point of the lamp HBO 103 W/2 and its slightly darker reflection become visible in the black glass window of the adjustment aid.
- Use the knurled button (Fig. 3-34/4) for collector adjustment in order to focus the lighter focal point.
- Use the adjustment screws (Fig. 3-34/2 and 3) to focus the darker focal point (reflection) in analogy to the focal point image (Fig. 3-33/2) in the inscribing adjustment circle.

 Both focal points of the HBO 103 W/2 lamp should be close to each other in the adjustment circle of the adjustment aid!

- Replace the adjustment aid in its original position.

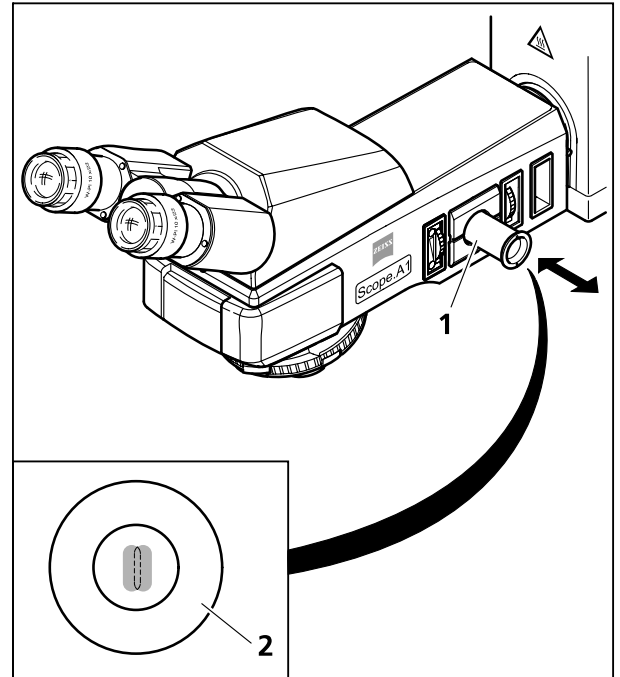

Fig. 3-33 Adjustment aid

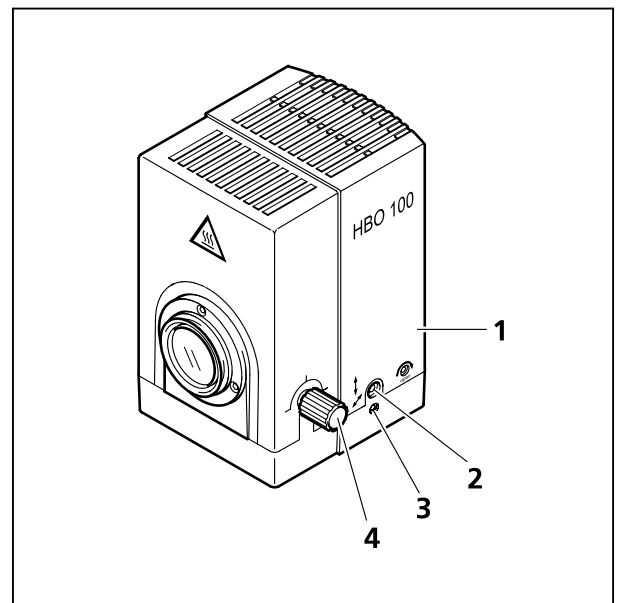

Fig. 3-34 Adjusting the HBO 100

3.1.19 Illumination System Colibri and External Illumination Fixture HXP 120

Please refer to the separate operation manual of Colibri and HXP 120 for installing and operating these systems.

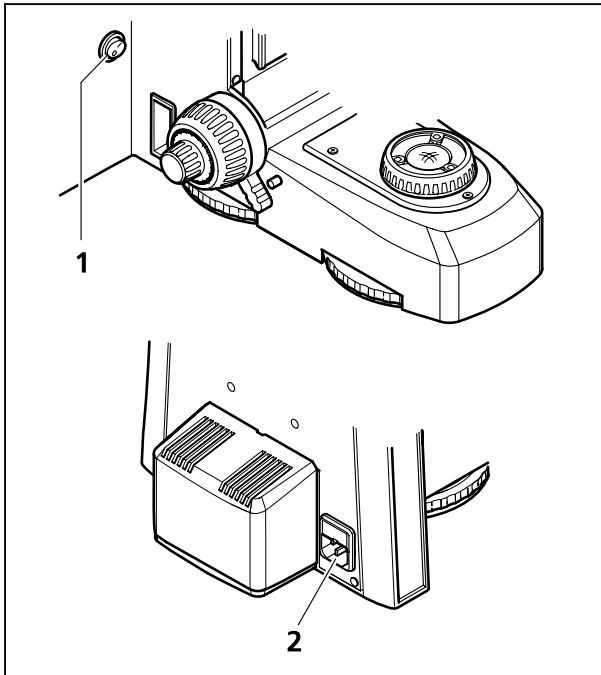

Fig. 3-35 Lower stand part for HAL 50 illumination (proceed analogically for LED illumination)

3.2 Connection of the Power Supply

3.2.1 Lower Stand Part for LED and HAL 50 Illumination

- Connect the microscope's power supply (Fig. 3-35/2) with its power cord to an electrical outlet. The microscope can adjust to a power and voltage range of 100 to 240 VAC, 50 ... 60 Hz. The power supply unit adjusts **auto-**
matically to the available voltage.

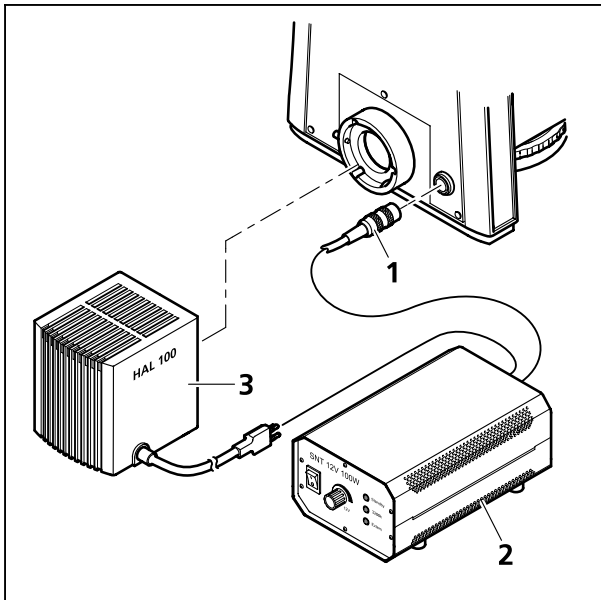

Fig. 3-36 Lower stand part for HAL 100 illumination

3.2.2 Lower Stand Part for HAL 100 Illumination

- Mount halogen lamp HAL 100 (Fig. 3-36/3) to the stand (see also chapter 3.1.15.1).
- Connect the 3-pin HAL 100 plug to the separate auxiliary power supply unit (Fig. 3-36/2).
- Connect the cable for light intensity control (Fig. 3-36/1) with the appropriate connecting socket on the back of the stand or on the auxiliary power supply unit (Fig. 3-36/2).

3.2.3 Upper Stand Part for HAL 100/HBO, FL/HBO, FL-LED

- Mount the halogen lamp HAL 100 to the stand (see chapter 3.1.15.1).
- Connect the 3-pin HAL 100 plug to the separate auxiliary power supply unit (Fig. 3-37/3).
- Connect the power cord of the auxiliary power supply unit (Fig. 3-37/4) with an electrical outlet.

Or

- Connect the HBO 100 plug to the transformer HBO 100 W (Fig. 3-38/2), then connect the power supply (Fig. 3-38/3) of the transformer to an electrical outlet.

Or

- Connect the external ac adapter of the upper stand part FL-LED (with integrated LED-illumination) to an electrical outlet.

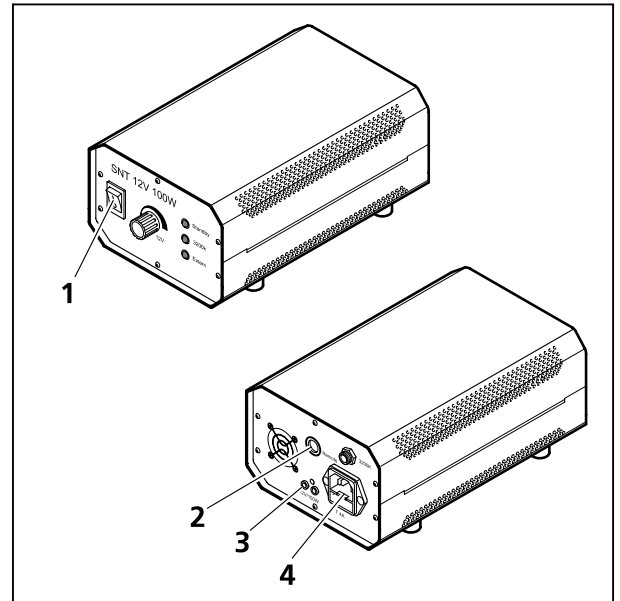

Fig. 3-37 Auxiliary power supply unit HAL 100 (front and back)

3.3 Switching the Microscope and its Separate Illumination Fixtures on and off

- Turn the power switch (Fig. 3-35/1) of the microscope with lower stand part for LED or HAL 50 illumination either on or off.
- Switch on the halogen lamp for transmitted light (lower stand part for HAL 100 illumination) and reflected light (if in use) at its separate auxiliary power supply unit (Fig. 3-37/1) accordingly (also refer to the separate operation manual of the auxiliary power supply unit).
- Switch on or off the HBO 100 lamp for overhead fluorescence light (if in use) with the power switch of the transformer HBO 100 W (Fig. 3-38/1).
- Switch on the LED illumination on the upper stand part FL-LED directly (Fig. 4-23/2).

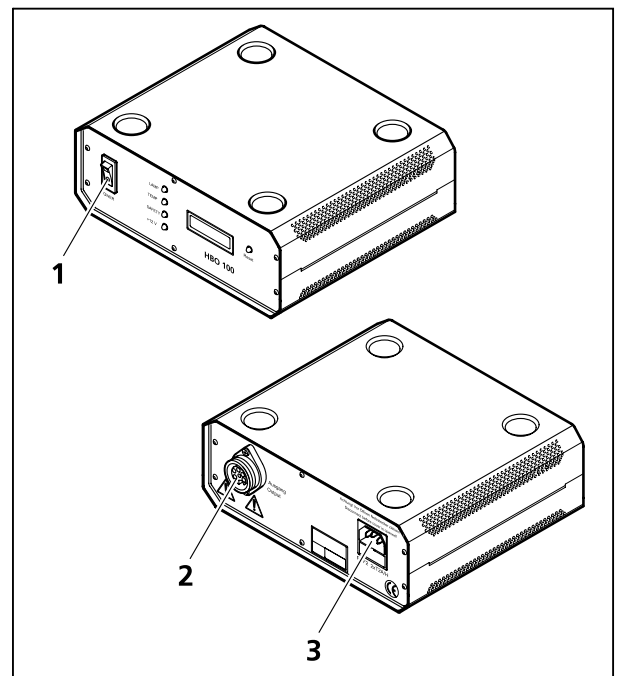

Fig. 3-38 Transformer HBO 100 W (front and back)

3.4 Mounting Optional Components



Make sure to unplug the stand and the external power supply units before you begin any mounting work.



After finishing working the appropriate components must be put back into functional condition (see chapters 3.1 to 3.3).

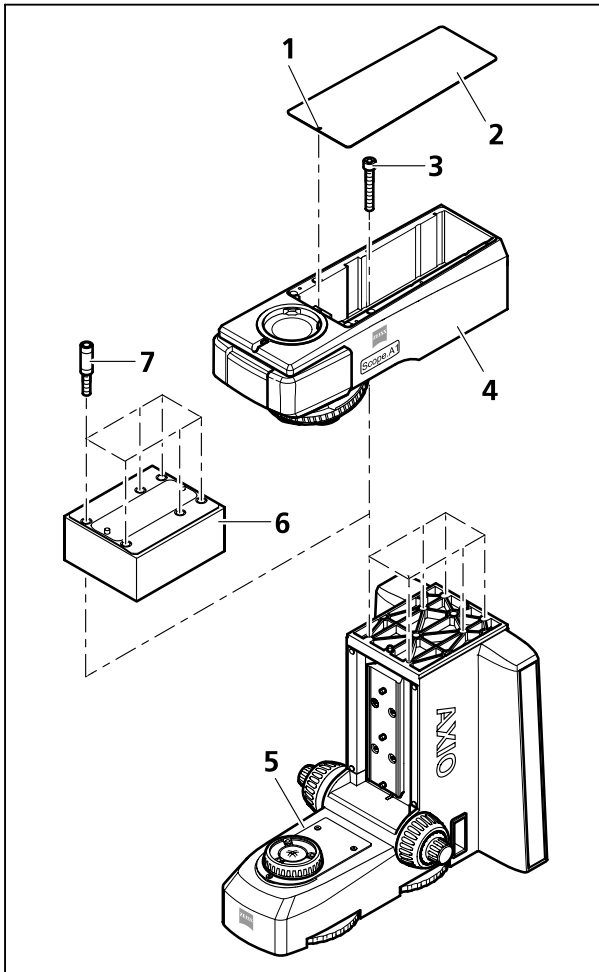

Fig. 3-39 Changing the upper stand part, inserting a centerpiece

3.4.1 Changing the Upper Stand Part and Inserting a Centerpiece for Larger Specimens

- Remove the magnetically held cover (Fig. 3-39/2) of the upper stand part by inserting a screwdriver into the special front opening (Fig. 3-39/1). Then lift the cover.
- Hold the upper stand part (Fig. 3-39/4), unscrew the six hexagon socket screws (Fig. 3-39/3) with the ball head screwdriver SW 5 and remove the upper stand part.
- If you want to mount a centerpiece (Fig. 3-39/6), then proceed by screwing the appropriate spacers (Fig. 3-39/7) with the included key SW 8 into the lower stand part. Then mount the centerpiece 30 mm or 60 mm.
- Mount the upper stand part to be mounted (Fig. 3-39/4) onto the lower stand part or the centerpiece, hold it and tighten the six hexagon socket screws (Fig. 3-39/3).
- Replace the cover.
- Check the stage carrier position and change it if necessary (see chapter 3.1.13).

3.4.2 Mounting the Intermediate Plate for Analyzer Slider

- Loosen the hexagon socket screw (Fig. 3-40/5) with the ball head screwdriver SW 3 and lift off the tube (Fig. 3-40/1).
- Use the included ring tool to unscrew the tube lens (accessible from the bottom) and keep it free of dust.
- Screw the tube lens included with the intermediate plate into the tube.
- Insert the intermediate plate (Fig. 3-40/2) with the dovetail ring into the stand socket (Fig. 3-40/6), adjust it, then fixate it with the hexagon socket screw (Fig. 3-40/4).
- Insert the analyzer slider into the slider receptacle (Fig. 3-40/3) if applicable.
- Slightly incline the binocular tube (Fig. 3-40/1) when inserting it into the intermediate plate, adjust it and fixate it with the hexagon socket screw (Fig. 3-40/4).

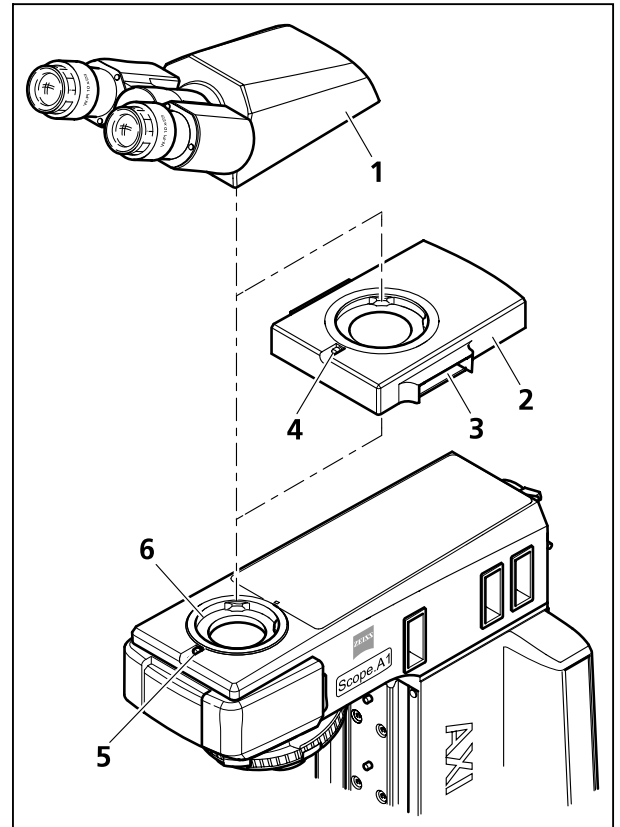

Fig. 3-40 Mounting the binocular tube

3.4.3 Mounting the Tube Lens Turret

Mounting the tube lens turret is done analogically to mounting the intermediate plate for analyzer sliders. See chapter 3.4.3.



Before using the TL turret, please remove the tube lens from the tube. Only in combination with imager tubes and eyepieces SF23 (see Systems Overview).

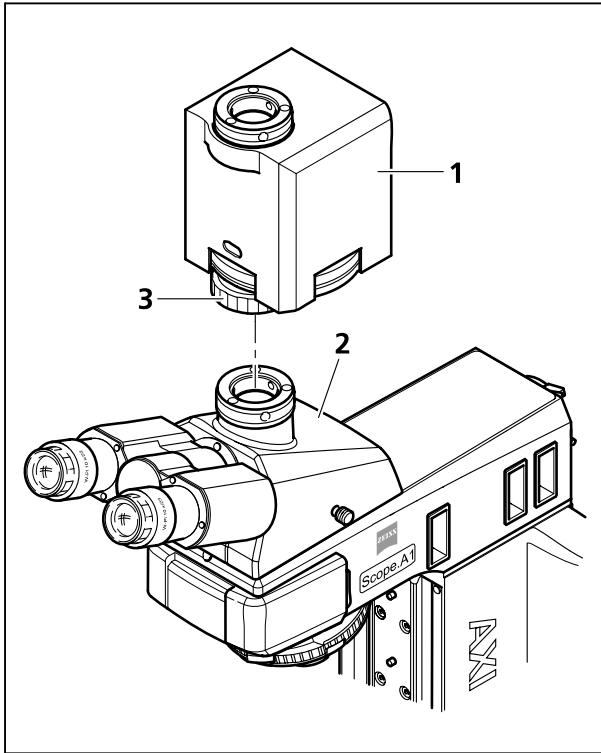

Fig. 3-41 Mounting the magnification changer

3.4.4 Mounting the Magnification Changer

- If necessary, remove camera with adapter (or dust protection cover) from the camera port of the photo tube (Fig. 3-41/2).
- Mount the magnification changer (Fig. 3-41/1) onto the camera port, adjust it and fixate it with the retainer nut (Fig. 3-41/3).
- Mount the camera with the appropriate adapter onto the camera port of the magnification changer.

The scanning power for changing the remagnification modules can be adjusted with the screw with a white circle on the bottom of the housing.

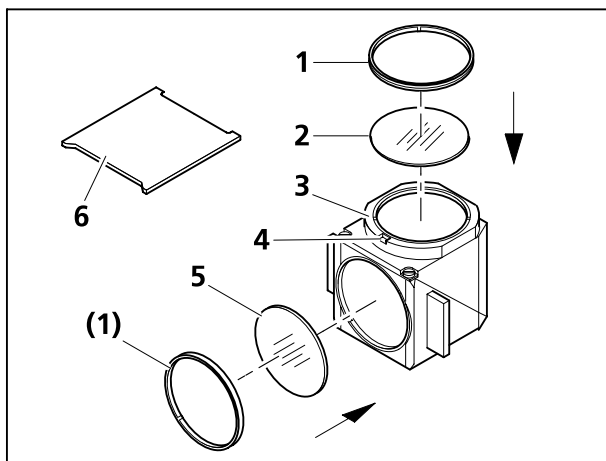

Fig. 3-42 Changing the filters in the reflector module FL P&C

3.4.5 Changing the Filters in the Reflector Module FL P&C

- Remove the reflector module FL P&C (Fig. 3-42/3) from the reflector turret and put it aside (see also chapter 3.1.6).
- Unscrew the adapter ring (Fig. 3-42/1) with the mounting plate included with the tools (Fig. 3-42/6).
- Turn over the reflector module and let the filter (Fig. 3-42/2 or 5) drop onto a soft surface.
- The emission filter is inserted in Fig. 3-42/2, the excitation filter in Fig. 3-42/5. Then fixate with the adapter rings (Fig. 3-42/1).

Emission and excitation filters can have a name and an arrow in the girth. The arrow indicates which way the filter must be mounted on the reflector module and should always point inward (see arrows in Fig. 3-42).

In order to minimize the image offset in multiple fluorescence images, the emission filter may have another mark to factor in the point angle.

When mounting the appropriate emission filter into the according reflector module, the mark should be aligned with the orientation groove (Fig. 3-42/4). This guarantees that the point angle in the reflector modules acts equally and compensates or minimizes the image offset – already low in Zeiss filter sets – even further.

When mounting a filter without any orientation marks (arrow), we advise to proceed like this:

Filters with reflecting, di-electrical coating are mounted so that the reflecting coating (Fig. 3-43/6) faces outward (in relation to the reflector module) in excitation filters (Fig. 3-43/5) and inward in emission filters (Fig. 3-43/2).

The reflecting coating (Fig. 3-43/4) of the color splitter (Fig. 3-43/3) faces down when mounted.

The arrows (Fig. 3-43/7) mark the path of the illumination beam or the imaging beam.

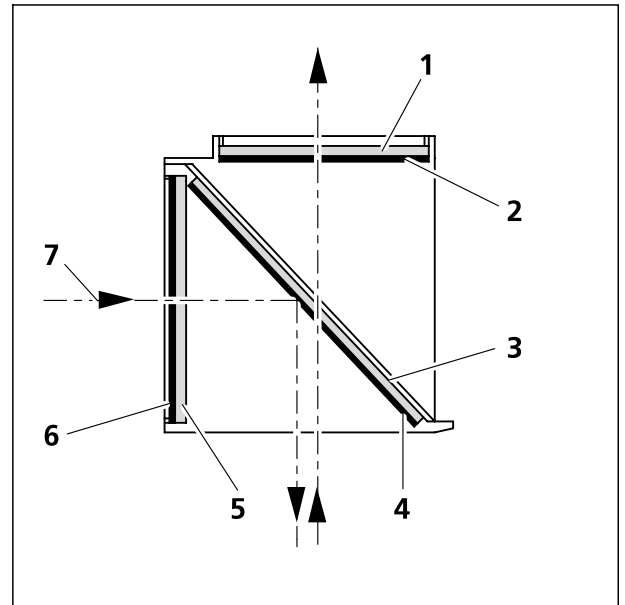

Fig. 3-43 Mounting the filters and the color splitter

3.4.6 Changing the Color Splitter in the Reflector Module FL P&C



Be extremely careful when mounting the filters and the color splitter in order to avoid damaging and soiling the optical components.

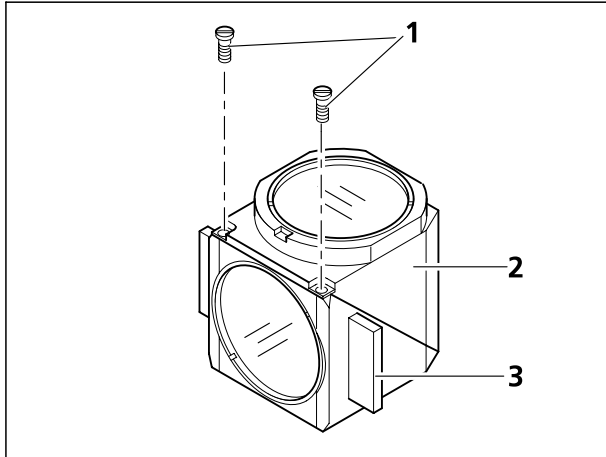

Fig. 3-44 Opening the module

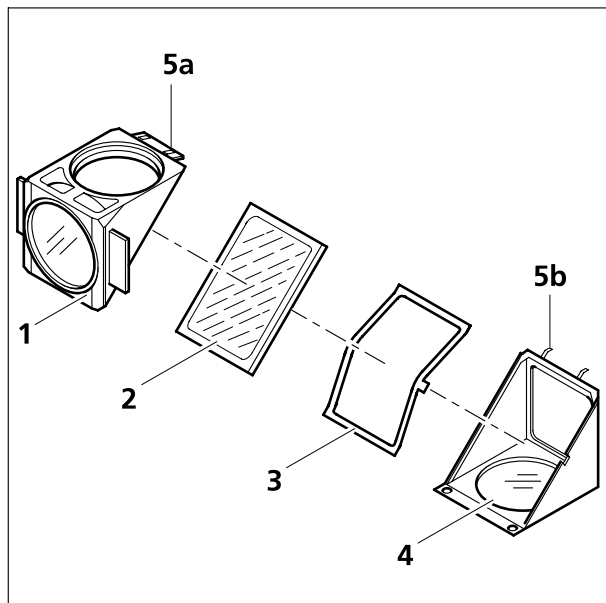



Fig. 3-45 Changing the color filter

We advise ordering completely equipped reflector modules FL P&C, as changing the color splitter is very challenging.

When changing the color filter, please proceed as follows:

- Remove the reflector module FL P&C from the reflector turret (see also chapter 3.1.6).
- Loosen both slit screws (Fig. 3-44/1) with a screwdriver.
- Hold both parts of the reflector module (the **emission** part (Fig. 3-44/2) and the **excitation** part (Fig. 3-44/3) together, turn them against the mounting position and put them down.
- Now tilt the **excitation** part, which lies on top (Fig. 3-45/1), upward and lift the **emission** part (Fig. 3-45/4) out of the holding fixtures (Fig. 3-45/5b).
- Remove color splitter (Fig. 3-45/2) and spring box (Fig. 3-45/3) from the bottom part of the module.
- Remove the old color splitter and put the new splitter with the reflecting coating facing up carefully on the spring box (Fig. 3-45/3). Put both pieces together into the bottom part of the module. Make sure that the side latch of the spring box is in the appropriate recess of the bottom part of the module.

 The reflecting (coated) side (Fig. 3-46/3) of the color splitter has a tapered edge (Fig. 3-46/1) or corner (Fig. 3-46/2).

- Put the **excitation** part of the module (Fig. 3-45/1) on the **emission** part (Fig. 3-45/4) – holding fixtures (Fig. 3-45/5b) and eyelets (Fig. 3-45/5a) latch together. Hold both parts together and turn them back into mounting position.
- Replace the slit screws and tighten them.
- Last, stick the sticker with the name of the filter combination on the side of the module.

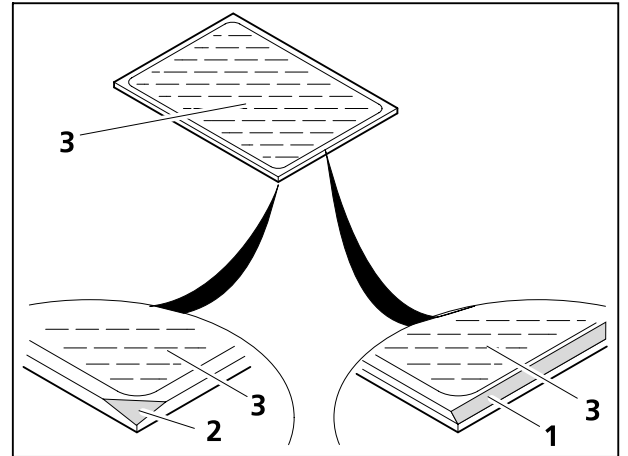

Fig. 3-46 Labeling the color splitter

3.4.7 Mounting the Polarizer D or the Filter Holder

- For an easy assembly, remove the condenser carrier (Fig. 3-47/3) fully, with the stage carrier.
- If necessary, unscrew stop bolt and bracket bolt with overview fixture from the condenser carrier.
- Hold the polarizer or filter holder (Fig. 3-47/6) parallel to the bottom of the condenser carrier (Fig. 3-47/3) and screw the bracket bolt (Fig. 3-47/4) of the polarizer (Fig. 3-47/6) with the angled adjustment lever (Fig. 3-47/5) in to the front threaded opening at the left below the condenser carrier (Fig. 3-47/3) until it stops.
- Screw the stop bolt (Fig. 3-47/2) with the adjustment lever (Fig. 3-47/1) to the stop into the back threaded opening of the condenser carrier (Fig. 3-47/3).

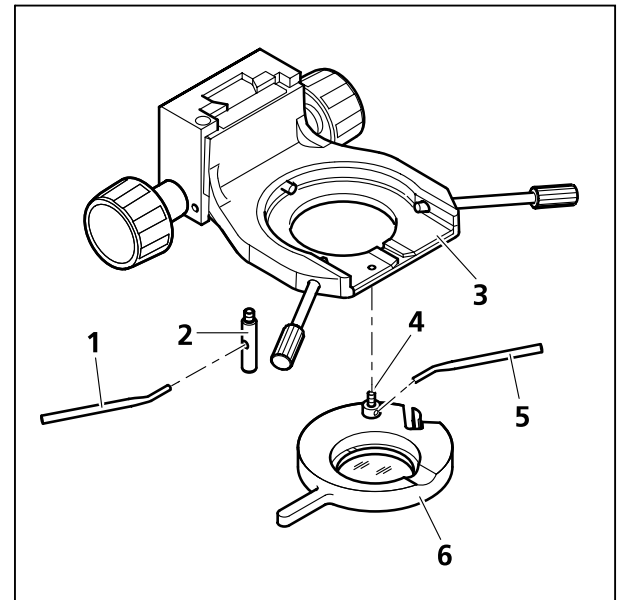

Fig. 3-47 Mounting the polarizer D

Proceed analogically when mounting the other components listed in the Systems Overview.

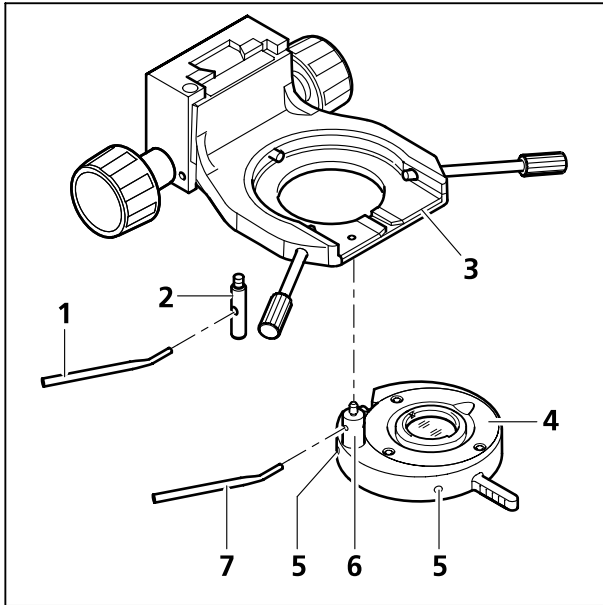

Fig. 3-48 Mounting the overview fixture

3.4.8 Mounting and Centering the Overview Fixture

- If necessary, remove polarizer or filter holder from the condenser carrier.
- Hold the overview fixture (Fig. 3-48/4) parallel to the bottom of the condenser carrier (Fig. 3-48/3) and screw the bracket bolt (Fig. 3-48/6) of the overview fixture with the angled adjustment lever (Fig. 3-48/7) into the front threaded opening to the left below the condenser carrier (Fig. 3-48/3) until it stops.
- With the adjustment lever (Fig. 3-48/1) screw the stop bolt (Fig. 3-48/2) into the back threaded opening of the condenser barrier (Fig. 3-48/3) to the stop.
- Retract the overview fixture into the beam path. Make sure that the fixture is securely engaged.
- Open aperture diaphragm and field diaphragm completely.
- Adjust both adjustment screws (Fig. 3-48/5) with the aid of two hexagon socket screwdrivers (SW 1.5) until the field of vision is well lit.



It only makes sense to mount the overview fixture on the condenser 0.9/1.25.

3.4.9 Changing the LED Module in the Upper Stand Part FL-LED

- Lift the covering caps (Fig. 3-49/1) off the upper stand part.
- Remove the connecting plug (Fig. 3-49/3) of the LED module to be changed (Fig. 3-49/2) from the corresponding slot (Fig. 3-49/4) and pull the LED module out of its socket.
- Put the new LED module into the socket and plug the cable into the corresponding slot. No adjustment is necessary.
- As the LED circuit is coupled to the reflector turret, it is necessary to make sure that LED module and fluorescence filters on the corresponding reflector turret position are compatible.

For better orientation, the positions of the LED module and those in the reflector turret are numbered.

- Replace the covers.



When you insert LED modules or fluorescence filters, make sure that they match spectrally. This guarantees that the correct LED is switched on when the reflector turret is rotated.

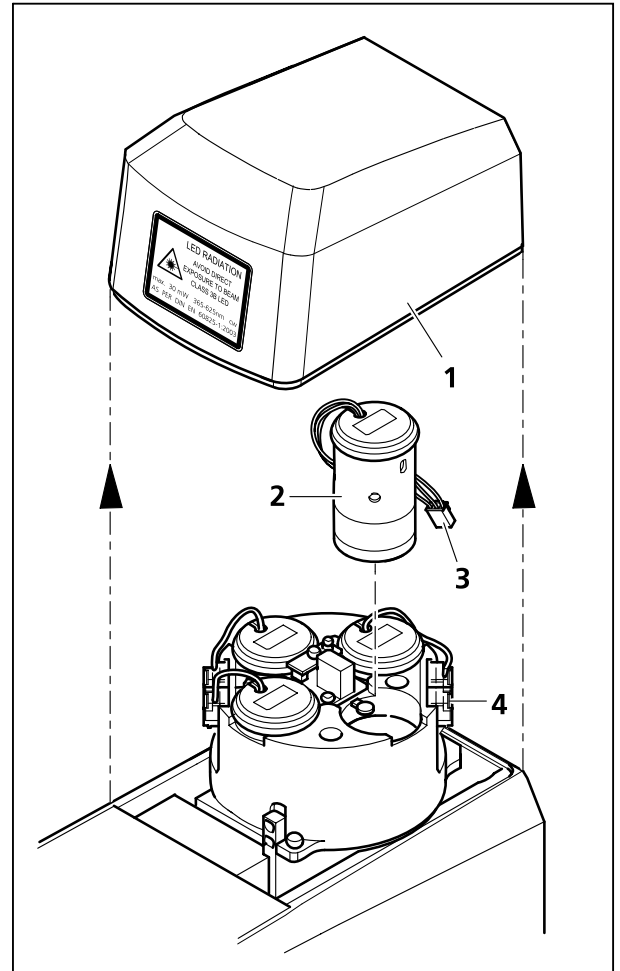

Fig. 3-49 Changing the LED module

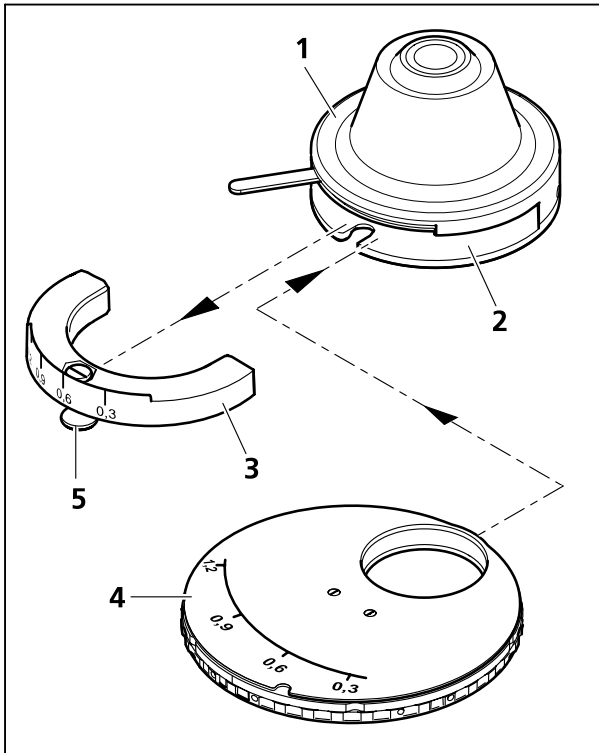

Fig. 3-50 Modulator disk in condenser
0.9/1.25 H

3.4.10 Inserting a Modulator Disk in the Condenser 0.9/1.25 H

- Remove the condenser (Fig. 3-50/1) from the condenser carrier (see chapter 3.1.12). If the condenser cannot be lowered sufficiently, e.g. with mounted overview fixture, then it might become necessary to remove it with the stage carrier, then lower it to the stop and remove the condenser.
- Loosen the clamping screw (Fig. 3-50/5) of the condenser's dial segment (Fig. 3-50/3) with the screwdriver (SW 3) and pull out the dial segment.
- Slide the modulator disk (Fig. 3-50/4) with its two-pronged forked opening pointing forward into the condenser. Make sure that the disk engages in the guide on both inner sides of the condenser. The guide serves as a stop for the modulator disk. The pin of the disk's clamping screw must slide into the orientation groove of the condenser.
- Tighten the disk's clamping screw with the screwdriver (SW 3).
- Replace the condenser into its carrier (see chapter 3.1.12).

3.4.11 Changing the Diaphragm PlasDIC

How to mount the slit-diaphragm (426715-9000-000):

- Turn the Ph-diaphragm which needs to be changed into the free aperture of the modulator disk.
- Screw the modulator disk's centering screws (Fig. 3-51/5) with the aid of a hexagonal socket screwdriver back until they stop.
- Unscrew the adapter ring (Fig. 3-51/2) of the Ph-diaphragm with the included tool (Fig. 3-51/1).
- Remove Ph-diaphragm (Fig. 3-51/4) and spring (Fig. 3-51/3).
- With the aid of the tool (Fig. 3-51/1), insert the slit-diaphragm (Fig. 3-51/7) with the cams into the orientation grooves (Fig. 3-51/6).
- Screw in the adapter ring (Fig. 3-51/8) included with the slit-diaphragm with the aid of the appropriate tool (Fig. 3-51/1).

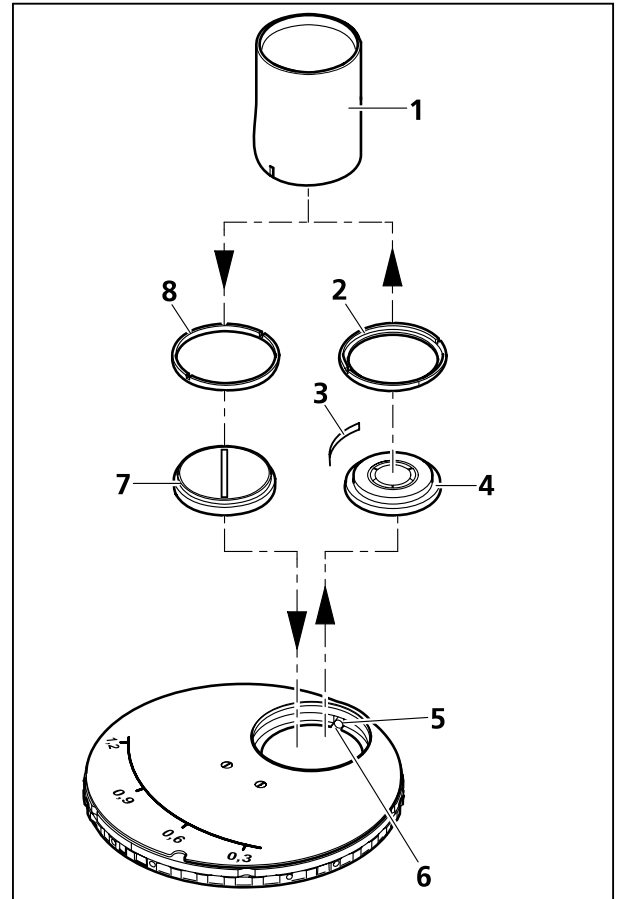

Fig. 3-51 Mounting the slit-diaphragm

3.4.12 Changing the Diaphragm Ph-DIC on the Achromatic-Aplanatic Condenser 0.9 H D Ph DIC

The diaphragm is changed according to the directions given in chapter 3.4.10.



After inserting the DIC module, do not tighten the condenser's centering screw again.

How to deactivate the pre-set diaphragm mechanism which automatically opens the diaphragm when phase contrast occurs:

- Remove the cover (Fig. 3-52/1). Turn the screw (Fig. 3-51/5) with the hexagon socket screwdriver 1.5 mm counter-clockwise to the stop. You can now close the aperture diaphragm for contrasting procedures in DIC.

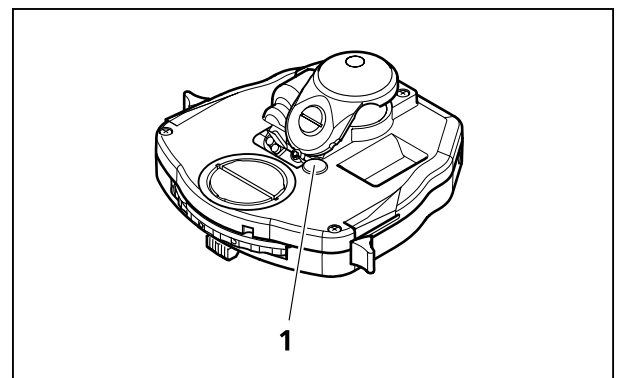

Fig. 3-52 Changing the diaphragm Ph-DIC

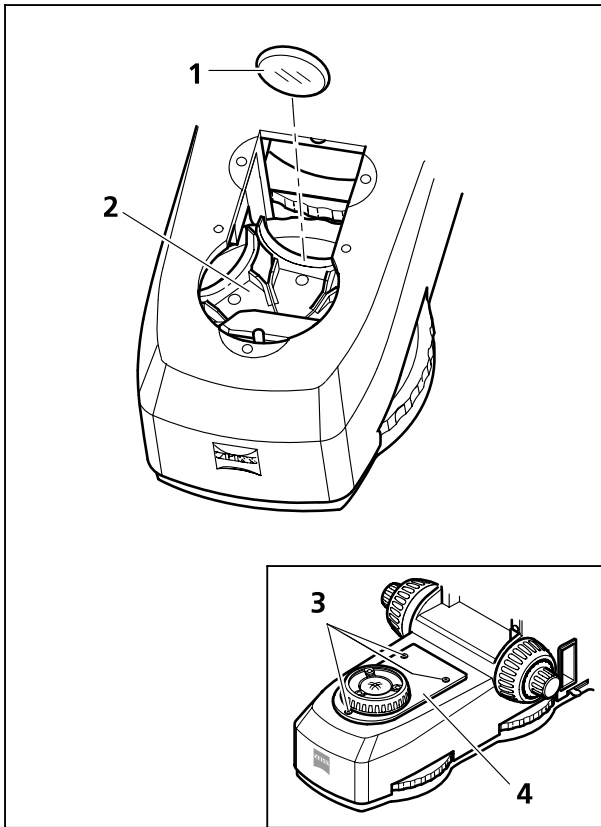

Fig. 3-53 Changing the filter in the filter wheel transmitted light

3.4.13 Changing the Filter in the Filter Wheel Transmitted Light

- Remove the stage carrier (see chapter 3.1.11).
- Unscrew three screws (Fig. 3-53/3) of the field diaphragm socket (Fig. 3-53/4) and pull the socket out of the stand foot.
- If necessary, pull the filter to be changed (Fig. 3-53/1) out of the corresponding position of the filter wheel (Fig. 3-53/2).
- Put the new filter into the position.



A filter position is always designed as firmly installed shutter position.

- Repeat the procedure for all filter wheel positions.
- Put in the field diaphragm socket and screw it in.
- Mount the stage carrier (see chapter 3.1.11).

3.5 Default Setting of the Microscope

3.5.1 Adjusting the Eyepiece Distance (Distance of the Pupils) on the Binocular Tube

- Adjust the eyepiece distance (distance of the pupils) according to the individual distance of the operator's eyes (Fig. 3-54).

The distance is good as soon as the operator sees only **one** round image when looking through both eyepieces!

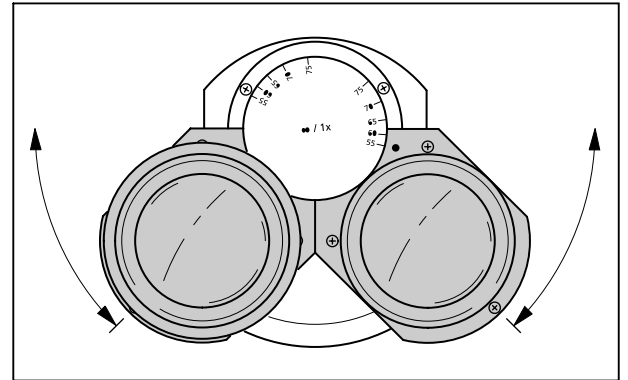

Fig. 3-54 Adjusting the eyepiece distance on the binocular tube

3.5.2 Adjusting the Viewing Height

- Adjust the viewing height to the individual needs by swinging the eyepiece barrel upward (Fig. 3-55/A) or downward (Fig. 3-55/B).

The binocular ergonomic (photo) tubes (425511-0000-000, 425512-0000-000, 445514-0000-000 and 425520-9050-000) are equipped with a continuous height adjustment in the range from 44 mm to 50 mm.

The binocular piece of the ergo tube 425520-9050-000 can also be pulled out horizontally by 50 mm.

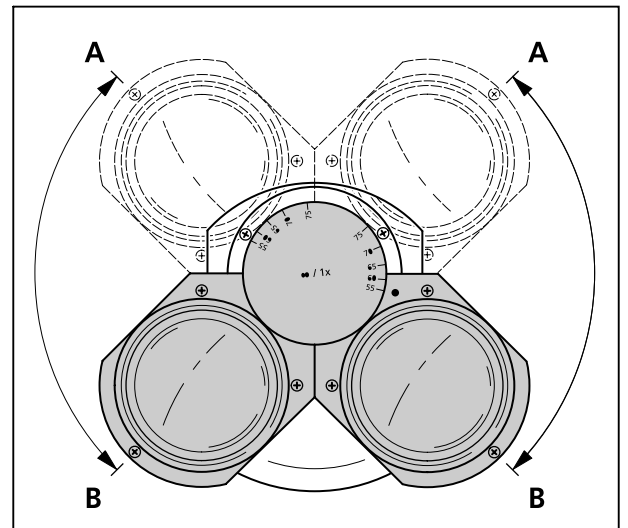

Fig. 3-55 Adjusting the viewing height on the binocular tube

3.5.3 Correction of Vision Defects with the Eyepiece Graticules

If you are going to use an eyepiece graticule you will need two adjustable graticules, e.g. PL 10x/23 Br. foc., in order to correct different vision defects of different operators.

- Focus the lens of the adjustable eyepiece on the grid in the eyepiece graticule.
- Using the focusing drive, focus the eyepiece with the graticule on a microscopy image of an object.
- When microscopy image and graticule look sharp in this eyepiece, focus the image for the other eye with the adjustable eye lens of the other eyepiece.

Now both microscopy images and the graticule look sharp. Any adjustment of the focus should now be performed with the focusing drive only.

4 OPERATION

4.1 Illumination and Contrasting Method

4.1.1 Adjusting the Transmitted Light/Bright-Field According to KÖHLER

(1) General principle of operation

The transmitted light/bright-field microscopy method is among all optical microscopy methods the one which is most commonly used. High-contrast or tinted samples (e.g. a blood smear) can be examined easily and quickly.

For an imaging result which is as true to the object as possible we need not only consider the so called direct bundled beams but just as well the indirect ones, i.e. the beams which diffract and scatter on the sample details. According to ABBE, the image is more true to the object when the fraction of the indirect bundled beams is as larger as possible.

The best performance of the microscope, and especially its objective, is achieved when condenser, field diaphragm and aperture diaphragm are adjusted according to the KÖHLER illumination principle. These fundamental basic rules for adjusting a microscope are explained in detail in chapter 4.1.1 (3) "Adjusting the transmitted light/bright-field according to KÖHLER".

(2) Instrumentation transmitted light/bright-field

Every microscope (except the one with the stand column Vario) is configured to work with the transmitted light/bright-field method.

All available condensers (except special condensers like dark-field condensers) can be used for the transmitted light/bright-field method.

(3) Adjusting the transmitted light/bright-field according to KÖHLER

- The Axio Scope.A1 has been put into operation appropriately (chapter 3).
- The Axio Scope.A1 is turned on.
- Adjust image brightness with light intensity control (Fig. 4-1/2) on microscope stand.
- Put high-contrast sample into object holder of mechanical stage.
- Bring front lens on condenser (if in use) into place (in objectives $\geq 10x$) and turn the gear knob for vertical adjustment of the condenser (Fig. 4-1/3 and Fig. 4-2/2) to the top stop. Make sure the stop is adjusted in a way to prevent the condenser from lifting out the sample (adjusting the condenser stop, chapter 4.1.1 (4)).
- On condensers with revolver/modulator disks: turn the knurled ring (Fig. 4-2/3) to position **H** (bright-field).
- Bring objective 10x in place on nosepiece (Fig. 4-1/6) and focus sample with gear knob (Fig. 4-1/1).
- Close field diaphragm (Fig. 4-1/5) enough to make it visible in field of view (even if blurred) (Fig. 4-1/A).
- Lower condenser with gear knob for vertical adjustment until edge of field diaphragm appears sharp (Fig. 4-1/B).

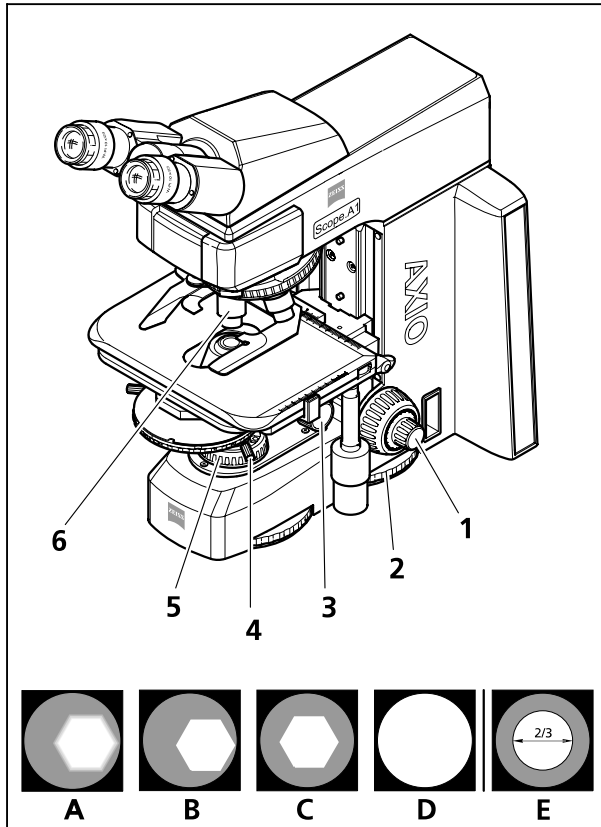



Fig. 4-1 Microscope adjustment in transmitted light/bright-field

- Center the field diaphragm image with both centering screws (Fig. 4-1/**4**) on the condenser carrier (Fig. 4-1/**C**). Open the field diaphragm enough to make the edge of the diaphragm disappear from the field of view (Fig. 4-1/**D**).
- In order to adjust the aperture (contrast), take an eyepiece from the tube barrel. Looking through the barrel adjust the aperture with the adjusting lever (Fig. 4-2/**4**) to the size of approx. $2/3$... $4/5$ of the diameter of the objective exit pupil (Fig. 4-1/**E**). In most cases this aperture gives the best contrast at almost full resolution and is thus the best compromise for the human eye.
- Replace eyepiece in tube barrel.

 Each objective changes the size of the object field and the objective aperture. The centering might also vary slightly from objective to objective, so that an adjustment of field diaphragm and aperture might become necessary for optimal results.

When using objectives $< 10\times$, the front lens of the condenser (if swivel-mounted) must be folded out and the aperture opened fully. In order to achieve a better contrast, the field diaphragm can be pulled closer when working with large object fields. To do this you must reduce the opening by a certain range. Avoid closing it too much in order to guarantee a consistent illumination of the field of view.

 A bright-field adjustment according to KÖHLER is not possible when using transmitted light LED.

(4) Adjusting the vertical stop on the condenser carrier

- Loosen the setscrew (Fig. 4-2/1) on the vertical stop with the ball-head screwdriver SW 3.
- Focus the sample with the focusing drive.
- Close the field diaphragm and adjust the condenser vertically (Fig. 4-2/2) until you get a sharp image.
- Perform the vertical adjustment on the condenser by small increments only to avoid lifting out the sample.
- Tighten the setscrew (Fig. 4-2/1) on the vertical stop.

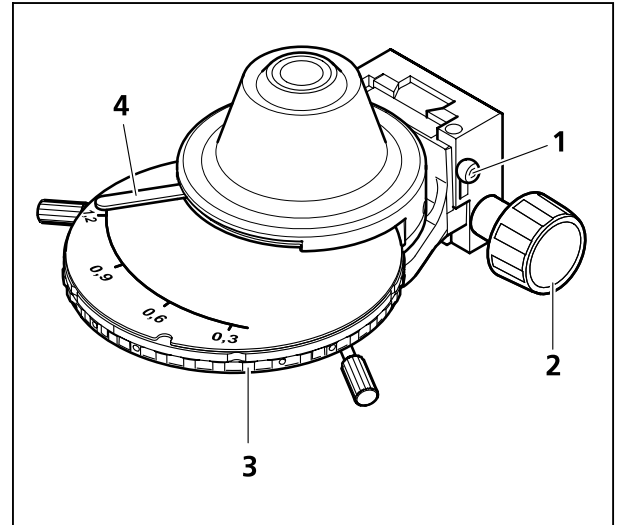

Fig. 4-2 Adjusting the vertical stop on the condenser carrier

(5) Adjusting the vertical stop on the focusing drive

- Turn the clamping lever (Fig. 4-3/1) of the stop towards the pin stop.
- Move the stage with the aid of the focusing drive (Fig. 4-3/2) to the highest position allowable without risking colliding with object carrier or objectives.
- Now press the clamping lever down until the stop engages again.

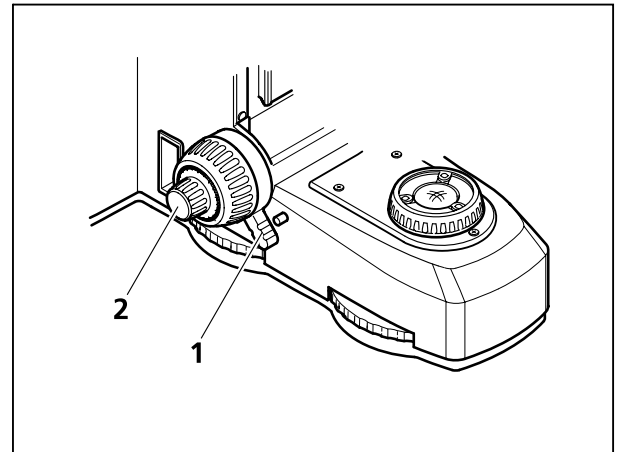

Fig. 4-3 Adjusting the vertical stop on the focusing drive

4.1.2 Adjusting the Transmitted Light/Dark-Field According to KÖHLER

(1) General principle of operation

Uncolored biological samples, like bacteria or living cell cultures, are sometimes hard to see in the transmitted light/bright-field due to their translucence. Yet it is completely different when you examine these samples with the transmitted light/dark-field method. You basically illuminate the sample with an illumination aperture which is higher than the one of the objective you are using.

In the dark-field, only the diffracted and scattered light portions which are important for the imaging procedure get into the objective, whereas the indirect unaffected light beams are directed past the objective. Thus a resolution of fine structures is achieved which is partially below the resolution capacity of a light microscope. The fine structures now appear bright and incandescent on a dark background.

(2) Instrumentation

Condenser with transmitted light stop in position **D** e.g.:

- Condenser 0.9/1.25 H with modulator disk H, D, Ph 1, Ph 2, Ph 3,
- Condenser, achrom.-aplan. 0.9 H D Ph DIC,
- Dark-field condenser with dry dark-field,
- Ultra condenser.

(3) Adjusting the transmitted light/dark-field

- Adjust the illumination according to KÖHLER in analogy to the transmitted light/bright-field. Instead of the 10x objective it is necessary to use a objective with the highest possible aperture. The aperture must not exceed the border aperture of the dark-field with the used condenser.
- Adjust revolver- / modulator disks to position **D** and bring in condenser front optic (if applicable).
- Take eyepiece out of the tube (or replace it by the auxiliary microscope) and check the centering of the dark-field diaphragm in the objective exit pupil. If the central dark-field diaphragm **D** in the universal condenser lies partially outside or is not centered to the objective exit pupil and the pupil does not appear consistently dark, then it is necessary to re-adjust the centering of the dark-field diaphragm.
- If the dark-field diaphragm needs to be centered, please use both Allen screwdrivers SW 1.5 (Fig. 4-4/1 and 4) and adjust the two centering screws (Fig. 4-4/2 and 3) until the objective exit pupil appears consistently dark. Remove the Allen screwdrivers SW 1.5 from the condenser after finishing the centering procedure.



Objectives with built-in iris apertures have apertures which are too high for the transmitted light/dark-field. Stop the iris aperture down at least until it reaches the border aperture for the dark-field of the condenser in use.

Performance criterion for the dark-field method is always a back ground for the field of view which should be as dark as possible

- Replace the eyepiece into the tube.
- Lighter areas which might still be visible in the field of view are reduced when the dark-field condenser is adjusted correctly and delicately. You now have an approximately sharp eye diaphragm image.
- Now adjust the field diaphragm diameter to the size of the field of view.

Dark-field samples need to be kept impeccably clean, more so than samples for any other method. A fingerprint, dust or any dirt particle can have a negative effect, as they brighten the background and reduce the contrast of the object image.

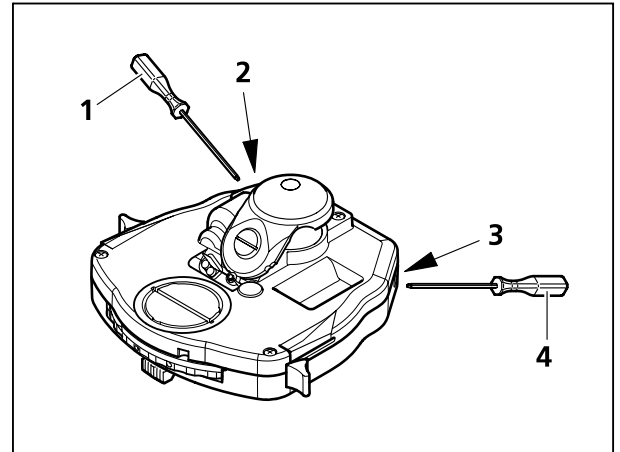

Fig. 4-4 Centering the dark-field diaphragm on the condenser, achromatic-aplanatic 0.9 H D Ph DIC

4.1.3 Adjusting the Transmitted Light/Phase-Contrast

(1) General principle of operation

The phase-contrast method is ideal for examining thin uncolored samples, e.g. culture cells. Generally the human eye cannot detect phase differences (variations in refractive index or thickness) within the different cell components.

The phase-contrast method converts with the aid of optical modulators, such as "annular phase diaphragm and phase ring", the small phase differences into intensity and color differences which are visible to the human eye. Important for the generation of such images is the interference of different beams in the intermediate image.

With the aid of the optically defined ring channel "annular phase diaphragm and phase ring", the high-intensity direct light portions are damped and provided with a constant phase shift. The indirect light portions, however, which are diffracted by different cell particles, bypass this optical channel and their phase is affected by the difference in the sample's refractive index and thickness.

In the intermediate image plane, the partial beams thus differently affected achieve interference and strengthen or weaken each other – depending on their phase. As a result, these interferences create image contents with intensity differences visible to the human eye.

(2) Instrumentation

- Phase-contrast objectives with the phase rings Ph 1, Ph 2 or Ph 3 for various medium numeral apertures which can also be used in the bright-field.
- Condenser with revolver / modulator disk which contains centerable ring diaphragms Ph 1, Ph 2 and Ph 3 for various medium numeral apertures.
- The phase annular diaphragm used on the condenser must be consistent with the labeling on the objective which is used, e.g. Ph 1.

(3) Adjusting the transmitted light/phase-contrast

- Put the phase-contrast objective, e.g. labeled **Ph 1**, into the beam path.
- Switch on the annular phase diaphragm on the condenser's revolver disk which has the same label as the phase-contrast objective, e.g. 1.
- In order to check the centering and the overlap of the lighter annular diaphragm (in the condenser) with the darker phase ring (in the objective), remove an eyepiece from the tube and replace it with an auxiliary microscope. Use the adjusting fixture on the auxiliary microscope to focus the annular diaphragm and the phase ring in the objective exit pupil.

- If the overlap is not exact (Fig. 4-5/**A**), the lighter annular diaphragm must be recentered with the aid of two hexagon screwdrivers SW 1.5 (Fig. 4-4/**1** and **4**). Adjust the two centering screws (Fig. 4-4/**2** and **3**) so that you achieve a full overlap with the darker phase ring (Fig. 4-5/**B**).
- Remove the auxiliary microscope from the tube and replace it with the eyepiece.

In order to increase the image contrast, an interference broadband filter, green 32 x 4, may be mounted on the field diaphragm or inserted into the color glass carrier (if available).

A complete phase contrast can only be achieved when the light-colored annular diaphragm (in the condenser) overlaps exactly with the dark-colored phase ring (in the object) in the illumination beam path (Fig. 4-5/**B**).

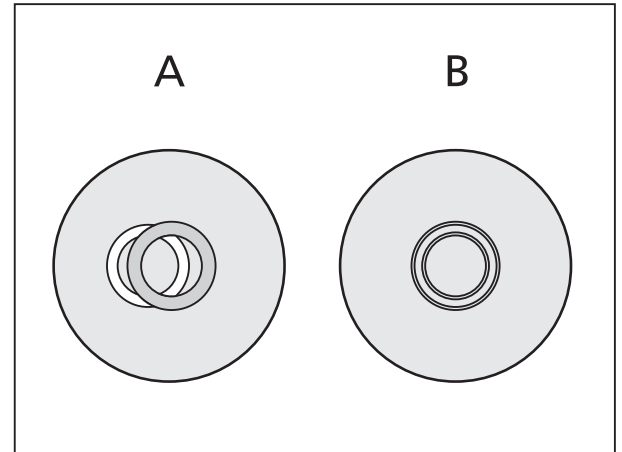

Fig. 4-5 Centering the annular phase diaphragm (light-colored, in the condenser) and the phase ring (dark-colored, in the object)

4.1.4 Adjusting the Transmitted Light/Differential Interference Contrast (DIC)

(1) General principle of operation

The transmitted light/DIC method allows for a high-contrast vivid display of transparent sample details.

The light is linearly polarized by a polarizer and is separated into two beams in a birefringent prism. The two beams penetrate two parts of the sample which are closely separated. They experience different path differences due to the different refractive indices or different sample thickness. Both beams are then reunited in a second double refractive prism and have after passing the analyzer the same polarization. Therefore both beams can interfere in the intermediate image and the path differences are thus converted into intensity differences represented by a grey scale. A compensator or λ -plate may be used for a consecutive conversion of the grey scale in a color scale.

(2) Instrumentation

- Objectives equipped with DIC fixtures, e.g. EC-Plan-Neofluare
- Nosepiece with slot for DIC slider
- DIC slider, compatible with the objectives in use
- Condenser with turret disk containing DIC prisms (e.g. condenser, achromatic-aplanatic 0.9 H D Ph DIC)
- Analyzer module ACR P&C for transmitted light in the reflector turret/slider or analyzer slider D/A fixated or rotatable in connection with a mounted intermediate plate for analyzer slider 12x46
- Rotatable mechanical stage, if necessary

(3) Adjusting transmitted light/DIC

- Put the DIC compatible objective (Fig. 4-6/3) in place on the nosepiece. Slide the according DIC slider (Fig. 4-6/1) into the slit of the appropriate objective position. Make sure that the slider engages firmly.
- Swing in the analyzer module (Fig. 4-6/6) on the reflector turret (Fig. 4-6/7) (or slide the analyzer slider into the intermediate plate for analyzer sliders).
- Swing in the DIC prism (position **DIC** on the condenser (Fig. 4-6/4).
- Adjust field diaphragm and aperture diaphragm according to the KÖHLER method.
- Adjust the optimal contrast on the DIC slider (Fig. 4-6/1) with the knurled screw (Fig. 4-6/2). Symmetrical adjustment of the DIC slider along its middle position lets the sample details appear as if they were elevated or deepened.
- If desired, the compensator λ (Fig. 4-6/5) can be put into the opening above the nosepiece in order to create a chromatic DIC contrast.

 The DIC method functions with polarized light. It is disturbed when birefringent elements, e.g. foils, are put between polarizer and analyzer, as is sometimes done when doing a histological incision. The same situation occurs with Petri dishes or specimen holders which have a plastic base. In these cases we advise using PlasDIC.

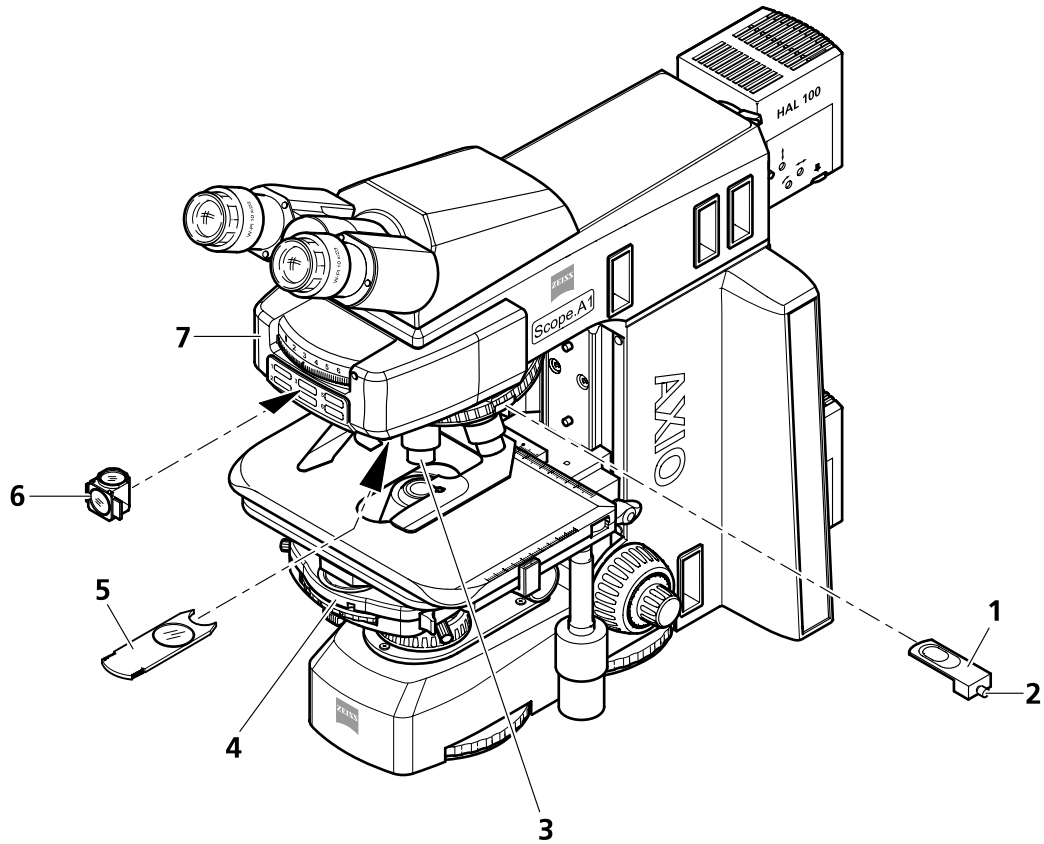

- 1 DIC slider
- 2 Knurled screw
- 3 Objective on the nosepiece
- 4 Condenser with DIC prism
- 5 Compensator λ
- 6 Analyzer module
- 7 Reflector turret

Fig. 4-6 Components for the transmitted light/DIC method

4.1.5 Adjusting PlasDIC-Contrast in Transmitted Light

(1) General principle of operation

PlasDIC can be used independently from the material of the specimen holder.

The contrast method gives a relief-like image and is especially well suited for thicker objects. The contrast is adjustable. It is possible to contrast the cavities of microtiter plates up to the edge. It is not necessary to use cultivation holders with a glass base.

(2) Instrumentation

- Abbe condenser with modulator disk and objective-dependent slit diaphragm 2 mm (A-Plan 10x and LD A-Plan 20x) or slit diaphragm 4.5 mm (in all other cases)
- Objectives:
 - A-Plan 10x, 20x, 40x;
 - LD A-Plan 20x, 32x, 40x;
 - LD Plan-Neofluar 20x, 40x, 63x
- Slider PlasDIC depending on the objective
- Analyzer module ACR P&C for transmitted light and reflector turret /slider or analyzer slider D/A fixated or rotatable in connection with mounted intermediate plate for analyzer slider 12x46

(3) Adjusting PlasDIC

- Fully open the aperture on the condenser.
- Put down the sample.
- Swing into the beam path the position with the slit diaphragm 2 or 4.5 mm for PlasDIC of the condenser. Increase brightness when switching from bright-field to PlasDIC.
- Swing analyzer module into the beam path or slide analyzer slider in beam path in intermediate plate.
- Swing in the objective for PlasDIC.
- Slide the slider PlasDIC on the nosepiece into the DIC slit of the used objective.
- Adjust the contrast with the knurled screw of the slider PlasDIC. You can now see the structures in relief or in pseudo dark-field. The best result is achieved in the relief mode.

4.1.6 Adjusting Transmitted Light/Polarization

4.1.6.1 How to show birefringence

(1) Application

The transmitted light/polarization method is used for samples which change the polarization of the light. Such samples are called birefringent. Examples are crystals, minerals or polymers. If such birefringent substances are observed between crossed polarizers, the birefringent portion of the sample appears bright while it's surrounding remains dark.

A birefringent substance can be recognized by turning the sample by 360° between crossed polarizers. The sample should show four bright and four dark appearances during the turning procedure. During the turning procedure, interference colors appear that range from grey (mostly for biological samples) through white, yellow and red until blue, depending on birefringence, thickness as well as sample orientation. The interference colors may be of first or higher order.

(2) Instrumentation

- Tension-free objectives
- Rotary stage Pol
- Polarizer D (rotatable or fixed), if no polarizer is already integrated in the condenser.
- Analyzer module ACR P&C for transmitted light in the reflector turret/slider or analyzer slider D fixed or with Lambda-plate.

(3) Adjusting the microscope

- Adjust the microscope as described in chapter 4.1.1 (3) for transmitted light/bright-field according to KÖHLER.
- Center the rotary stage Pol (Fig. 4-7/1).
- Swing the polarizer (Fig. 4-7/3) into the beam path and position it to 0° if you are using a rotatable polarizer.
- Put analyzer slider (Fig. 4-7/2) into the slit for the compensator or swing analyzer module in on the reflector turret/slider. Because of the crossed polarizers the field of view now appears dark.

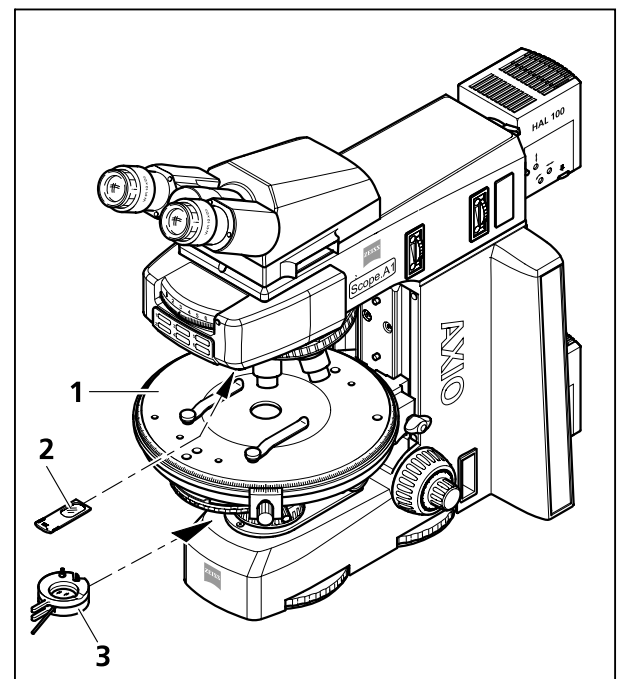

Fig. 4-7 Components for transmitted light polarization



If an analyzer slider is going to be used for working with the Axio Scope.A1, either the reflector module H P&C or an empty position must be swung in on the reflector turret/slider.

- Bring the object to be examined into the field of view and turn it with the rotary stage. Normally, birefringent (anisotropic) objects will now show the same color and intensity variations as described above during rotation between crossed polarizers. Optically anotropic substances may remain dark when an isotropic direction, e.g. from optically single-axle or double-axle crystals, is put parallel to the observation direction.

4.1.6.2 Determination of the Polarization Direction $n_{\gamma'}$

(1) Application

The determination of the polarization direction of n_{γ} or $n_{\gamma'}$ respectively (polarization direction with the absolute or relative largest index of refraction) and n_{α} or $n_{\alpha'}$ respectively (polarization direction with the absolute or relative smallest index of refraction) relative to the morphological directions, e.g. of crystal surfaces, crystal needles or fibers, provide an important signature of the material. This method is also used in the diagnosis of bio-crystals (e.g. gout and pseudo-gout).

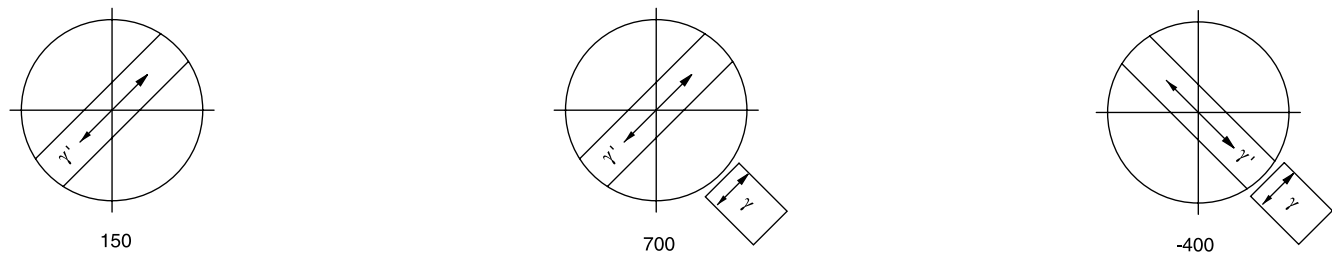

Fig. 4-8 Determination of the polarization direction $n_{\gamma'}$ in a synthetic fiber

(2) Instrumentation

- Eyepiece with graticule
- Tension-free objectives
- Rotary stage (Fig. 4-7/1)
- Polarizer D (rotatable or fixed), if not using a condenser with an integrated polarizer
- Analyzer module ACR P&C for transmitted light in the reflector turret/slider or analyzer slider D fixed or with Lambda plate
- Adjustment sample for polarization microscopy (453679-0000-000)

(3) Adjusting the microscope

- Adjust the microscope as described in chapter 4.1.1 (3) for transmitted light/bright-field. Make sure the eye distance is adjusted correctly on the binocular tube (see chapter 3.5.1).
- Center the rotary stage Pol (Fig. 4-7/1).
- Swing the polarizer (Fig. 4-7/3) in the beam path and position it to 0° if you are using a rotatable polarizer.
- Swing the analyzer module on the reflector turret in (Fig. 4-7/2) (or slide the analyzer slider into the intermediate plate). Because of the crossed polarizers the field of view now appears dark.
- Place the adjustment sample Pol on the microscope stage and turn until the sample appears dark.
- Switch off the analyzer and align the graticule along the split cracks of the object.
- Now switch the analyzer back on and remove the sample. The forward direction of polarizer and analyzer are now parallel to the graticule (Polarizer EW, Analyzer NS).
- Turn the rotary stage Pol with the sample, e.g. a synthetic fiber, so that the sample reaches maximal darkness. The fiber is now parallel to one of the two graticule directions. If the deflection is significant (5° and more) you will need to use a polarization microscope.



Do not change the eyepiece distance on the binocular tube any further in order to avoid shifting the angular position of the graticule to the fiber.

- Now turn the stage by approx. 45° until the longitudinal axis of the fiber is pointing in NE-SW direction (Fig. 4-9). The sample now shows the strongest brightness (diagonal position). The sample can have any color in this position.
- Slide in the compensator λ .

Like the sample, the compensator λ is a birefringent object, but it has a defined path difference of 550 nm and a maximum oscillation direction n_γ pointing strongly to NE-SW.

When the compensator λ is put in, the sample changes its color depending on its orientation (NE-SW or NW-SE).

The changes in color are based on optical interference. It is necessary to compare the interference colors (phase differences) in both diagonal positions (NE-SW and NW-SE).

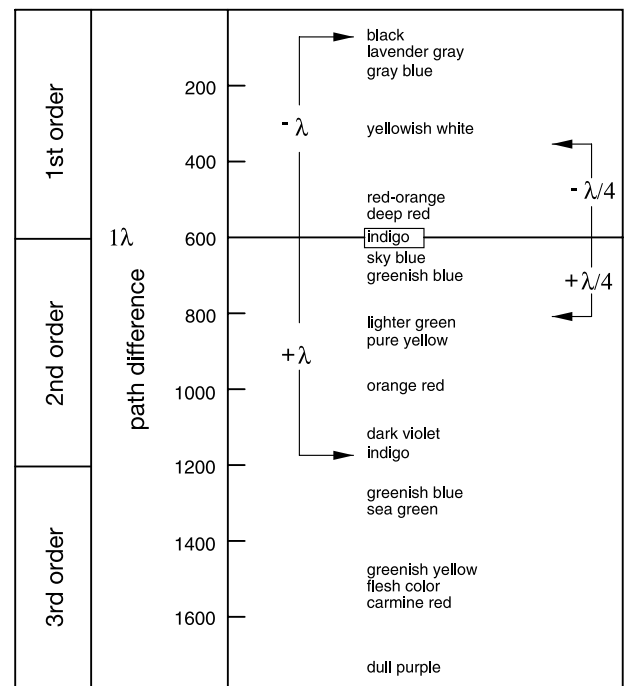

Fig. 4-9 Diagram of the color tables according to Michel-Lévy

The phase difference results from the interference of the polarization of the sample and the polarization of the compensator λ .

The larger phase difference occurs when the polarization direction of the sample or the absolute or relative largest index of refraction (n_γ or n_γ') is parallel to the largest polarization direction of the compensator λ . The sample appears then e.g. in blue-green.

The smallest phase difference occurs if the direction of polarization of the sample with the absolute or relative smallest index of refraction (n_α or n_α') is perpendicular to the polarization direction of the compensator λ . The sample then appears e.g. yellow.

(4) Conclusions

The color grey-white which occurs in the bright position as was discussed in the example above, corresponds according to the Michel-Lévy color table (Fig. 4-9) to a phase difference of 150 nm

The surrounding of the artificial fiber which is not birefringent shows after insurgence of the compensator λ a bright red which corresponds to a phase difference of the compensator of 550 nm (the interference color 1st order for the phase difference of 550 nm corresponds to 1λ).

If the polarization direction of the birefringence sample which is to be investigated is parallel to the largest polarization direction of the compensator λ , i.e. in NE-SW direction, the phase difference of the sample (i.e. grey-white: 150 nm) and the phase difference of the compensator λ (red: 550 nm) add up. This leads to a change in color of the sample from grey-white to blue-green (resulting phase difference = 700 nm).

If the polarization direction of the birefringence sample which is to be investigated is perpendicular to the largest polarization direction of the compensator λ , i.e. in NW-SE direction, the phase difference of the compensator λ (red: 550 nm) is subtracted from the phase difference of the sample (e.g. grey-white: 150 nm). This leads to a change in color of the sample from grey-white to orange (resulting phase difference = 400 nm).



Color tables according to Michel-Lévy can be ordered under ord. no. 42-312.

4.1.7 Adjusting the Reflected Light/Bright-Field According to KÖHLER

(1) Application

The reflected light/bright-field microscopy is the easiest and most commonly used optical microscopy method. It is used to examine optically opaque specimens or samples as e.g. cut material or wafers.

For an imaging result which is as true to the object as possible we need not only consider the so called direct bundled beams but just as well the indirect ones, i.e. the beams which diffract and scatter on the sample details. According to ABBE, the image is more true to the object when the fraction of the indirect bundled beams is larger.

The bundled light emerging from the reflected light illuminator is reflected on a color-neutral beam splitter before it passes through the objective which is focused on the specimen surface (so-called condenser function). The objective collects the light reflected on the object and creates, with the tube lens, the microscopic intermediate image. This image can then be examined visually or documented objectively.

(2) Instrumentation

- Axio Scope.A1 with adjusted halogen lamp HAL 100 mounted on the reflected light barrel
- Reflector module bright-field ACR P&C for reflected light in the reflector turret /slider
- Upper stand part HAL 100/HBO 6x HD, DIC with pre-installed aperture and field diaphragm or upper stand part HAL 100/HBO 6x HD, DIC and 2x diaphragm slider 14x40 mm

(3) Adjusting the reflected light/bright field

- The microscope is in correct operational mode according to chapter 3 .
- The microscope is switched on.
- Switch on halogen lamp HAL 100 on the separate auxiliary power supply unit (Fig. 4-10/1).
- Adjust light intensity with the control button on the auxiliary power supply unit (Fig. 4-10/2).
- Put a high-contrast reflected light sample on the microscope stage.
- Swing in objective 10x on the nosepiece (Fig. 4-11/6).
- Focus the sample with the focusing drive (Fig. 4-11/5). Try to focus away from the sample in order to avoid any collision between objective and sample.
- Put the knurled button of the aperture diaphragm (Fig. 4-11/2) to a medium position (approx. half open and half closed).

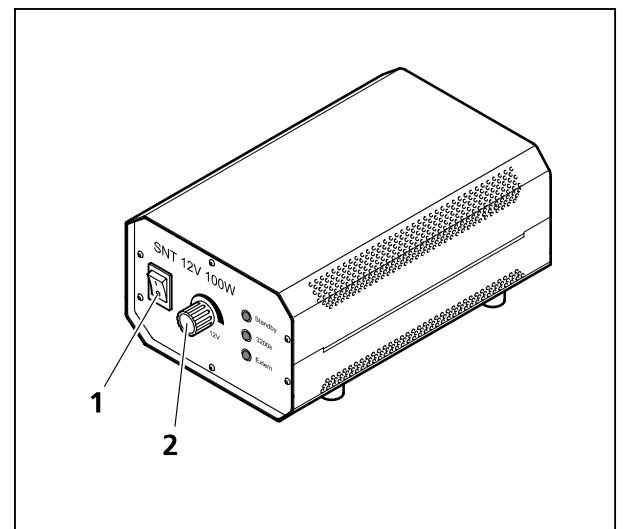



Fig. 4-10 External auxiliary power supply unit for HAL 100

- Adjust the knurled knob on the field diaphragm (Fig. 4-11/4) so that the field diaphragm becomes visible in the field of view (Fig. 4-11/A).
- Readjust the focus on the edge of the field diaphragm with the focusing drive (Fig. 4-11/B) and center the field diaphragm on the edge of the field of view (Fig. 4-11/C) with the centering screws (Fig. 4-11/3).
- Now open the field diaphragm enough to just make it disappear behind the edge of the field of view (Fig. 4-11/D).
- For adjusting the aperture diaphragm (image contrast) take out an eyepiece from the tube barrel and look into the barrel or mount an auxiliary microscope instead of the eyepiece.
- Center the aperture diaphragm with the centering screws (Fig. 4-11/1) and adjust the knurled knob (Fig. 4-11/2) to about 2/3 to 4/5 of the diameter of the objective exit pupil (Fig. 4-11/E) for samples with a medium contrast quality.

In most cases this position of the aperture diaphragm gives the best contrast at almost full resolution which is best compromise for the human eye.

- Replace the eyepiece and adjust the focus of the coaxial rough and fine drive and the image brightness according to the reflected light sample.

 Never use the aperture diaphragm to regulate the image brightness! Use the control knob on the auxiliary power supply unit to adjust the light intensity!

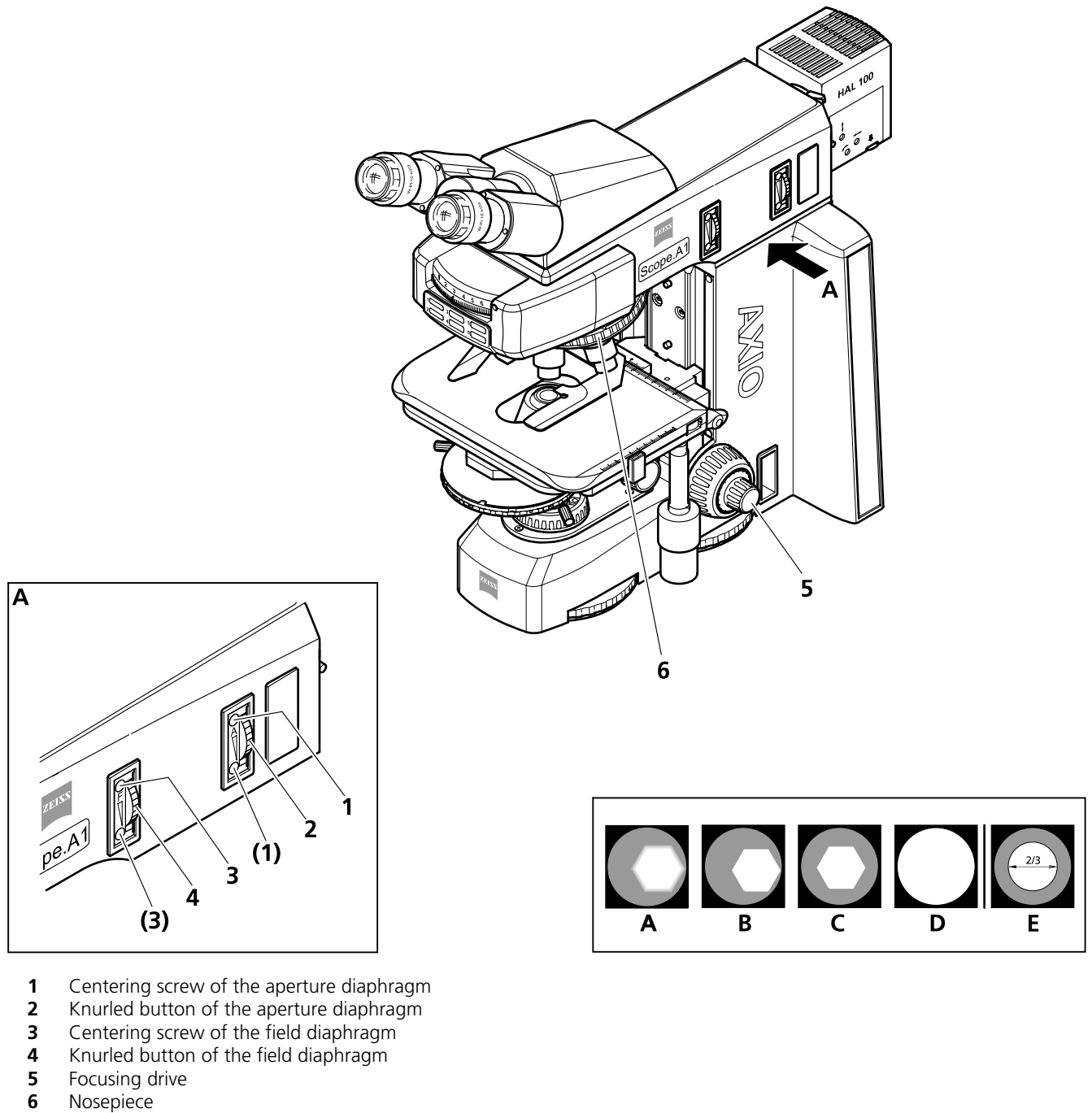

Fig. 4-11 Adjusting the microscope in the reflected light/bright-field

4.1.8 Adjusting the Reflected Light/Dark-Field

(1) Application

The reflected light/dark-field method is applied when samples are examined which do not have areas with different reflectivity (ideal bright-field samples), but which show scratches, cracks, pores (brief: deflections) on the plane surface. All such light scattering details appear bright in the dark-field while the reflective plane areas remain dark.

(2) Instrumentation

- Axio Scope.A1 with adjusted halogen lamp HAL 100 mounted on the reflected light barrel
- Objectives Epiplan-Neofluar, EC Epiplan-Neofluar, Epiplan with the additional label "HD"
- Reflector module dark-field ACR P&C for reflected light in the reflector turret/slider

(3) Adjusting the reflected light/dark-field

- Adjust the microscope as described in chapter 4.1.7 for reflected light/bright-field. The field diaphragm image should lie just barely outside of the edge of the field of view in order to avoid reflexes.
- Swing reflector module dark-field ACR P&C for reflected light on the reflector turret in the beam path.
- Remove condenser slider 6x20 if mounted.
- Swing in objective position with dark-field objective (HD) on the nosepiece.
- Open aperture diaphragm fully and switch off or remove neutral filters if applicable.
- Put down the sample and adjust the focusing if necessary.

4.1.9 Adjusting Reflected Light DIC and Reflected Light C-DIC

(1) Application

The reflected light DIC and the reflected light C-DIC methods (DIC = Differential Interference Contrast; C-DIC = Differential Interference Contrast in circular polarized light) are used for the high-contrast imaging of phase objects, i.e. objects which contrary to the amplitude objects, change predominantly the phase of the light.

(2) Instrumentation

- Axio Scope.A1 with adjusted halogen lamp HAL 100 mounted on the reflected light barrel
- Objectives EC Epiplan-Neofluar, Epiplan with the additional label "DIC" or "Pol"
- DIC slider, fitted to the objective engraved on the top surface of the slider with amplification and aperture or C-DIC slider 6x20 (in connection with the reflector module C DIC P&C, compensator compartment 6x20)

(3) Reflected light DIC, preferably for objectives Epiplan 5x to 100x and LD-Epiplan 10x to 100x

- Adjust the microscope for reflected light/bright-field as described in chapter 4.1.7. Open the field diaphragm enough so that the edge of the diaphragm lies just barely outside of the edge of the field of view in order to avoid reflexes.
- Swing the reflector module C DIC P&C on the reflector turret/slider in the beam path.
- Swing in objective position with DIC position on the nosepiece.
- Slide the DIC slider in the compartment of the nosepiece (above the objective).
- Put down the sample, focus and turn the mechanical stage so the structure of interest is visible with maximum contrast.
- The contrast can be optimized with the knurled button on the DIC slider.

(4) Reflected light C-DIC

- Adjust the microscope for reflected light/bright-field.
- Switch reflector module C DIC P&C into the beam path.
- Slide the C-DIC slider (Fig. 4-12/2) in the compensator compartment 6x20 (Fig. 4-12/1).
- Put the sample down, focus and turn the control knob (Fig. 4-12/4) on the C-DIC slider so the structure of interest is visible with maximum contrast. No further stage rotation is necessary.
- The contrast can be optimized by adjusting the control knob (Fig. 4-12/3) on the C-DIC slider.

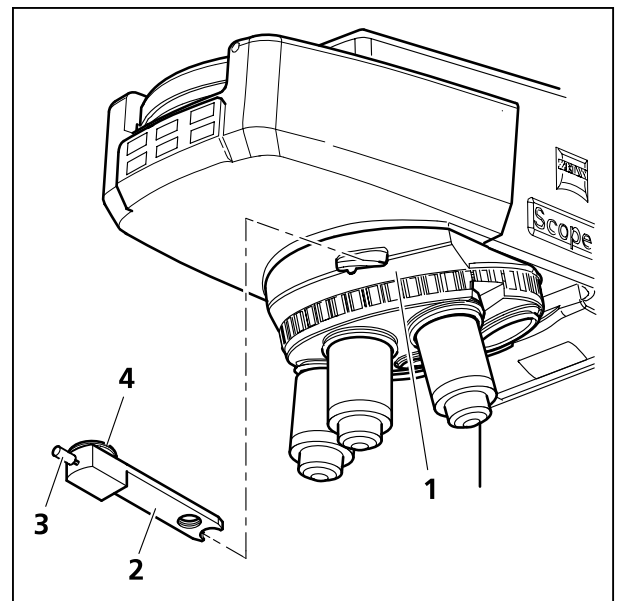

Fig. 4-12 Compensator compartment 6x20 with C-DIC slider 6x20

4.1.10 Adjusting Reflected Light TIC

(1) Application

The reflected light TIC method (Micro-interferometry; TIC = Total Interference Contrast in the circular polarized light) is used in imaging and measuring object structures which are on hand in different azimuths.

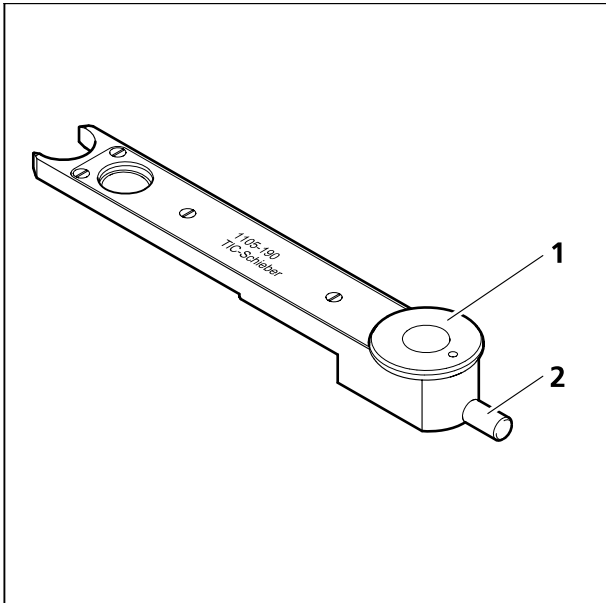

Fig. 4-13 TIC slider 6x20

(2) Instrumentation

- Axio Scope.A1 with adjusted halogen lamp HAL 100 mounted on the reflected light barrel
- Objectives EC Epiplan-Neofluar, Epiplan with additional label "DIC" or "Pol"
- Compensator compartment 6x20
- TIC slider 6x20 with appropriate reflector module C DIC P&C

(3) Adjusting reflected light TIC

- Put down the sample (e.g. a stepped object) and adjust the microscope for reflected light/bright-field as described in chapter 4.1.7.
- Swing reflector module C DIC P&C on the reflector turret in the beam path.

- Slide TIC slider 6x20 in the compensator compartment 6x20 (Fig. 4-12/1). You will see chromatic interference stripes in the field of view. Using the control knob (Fig. 4-13/2) of the TIC slider, move the black interference stripe by sight to the middle of the field of view.
- In order to choose the structure to be measured, turn the knob (Fig. 4-13/1) on the TIC slider until the interference stripes are vertical to the direction in which the object is broken down (see Fig. 4-14). The interference stripes can be shifted with the aid of the control button (Fig. 4-13/2).

The step-height d is then determined with the following formula:

$$d = \frac{n\Delta}{2} = \frac{\lambda b}{2a}$$

- With:
- d = step-height in nm
 - n = refractive index of the environment, mostly air ($n = 1$)
 - Δ = phase difference
 - a = distance between interference stripes
 - b = offset of the interference stripes along the step
 - λ = wave length of the illumination in nm

The values a and b (see Fig. 4-14) are determined with the aid of the eyepiece graticule micrometer or with the micrometer eyepiece.

If you work in the white light (without interference filter), you must set $\lambda = 550 \text{ nm}$. When interference filters are used, it is important to apply the focal point of their wave lengths.

The measured path difference depends on the aperture and increases with the illumination aperture.

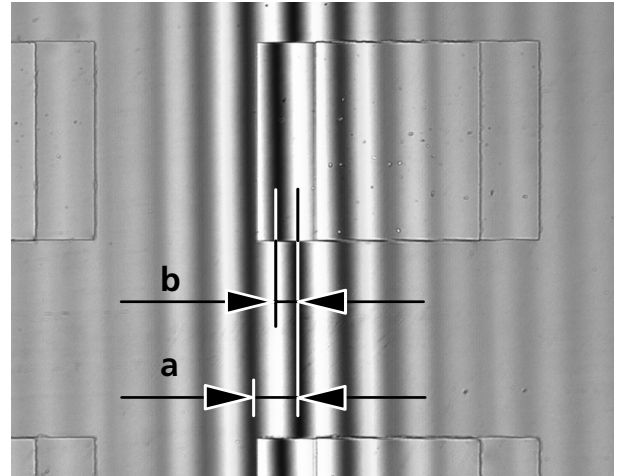

Fig. 4-14 Interference stripes

The following correction values must be considered depending on the used objective:

Objective	Correction factor k
5x/0.15	1.0057
10x/0.25	1.0161
10x/0.30	1.0236
20x/0.4	1.0436
20x/0.50 and 50x/0.75	1.0718
50x/0.60	1.1111
50x/0.75 and 100x/0.75	1.2038
50x/0.80	1.2500
50x/0.90 and 100x/0.90	1.3929
100x/0.95	1.5241

Table 1: Correction depending on aperture

Example:

a = 11 mm b = 5 mm
 $\lambda = 550 \text{ nm}$ objective 20x/0.50

$$d = \frac{\lambda \cdot b \cdot k}{2a} = \frac{550 \text{ nm} \cdot 5 \text{ mm} \cdot 1.0718}{22 \text{ mm}} = 134 \text{ nm}$$

Attention:

- If the step and its surrounding are made from different materials, the phase jumps characteristic for the material have to be considered. For all non-conducting materials the phase jump is 180° , and for all semi-conductors only slightly different from 180° . Consequently, errors in the step-height determination may be neglected. However, if metals on top of glass are investigated, the results may become erroneous. The phase jumps given in table 2 were calculated for vertical light incidence and compact materials. They can serve as approximate values, since the phase jumps depend on the layer-thickness and the angle of incidence of the light. An accurate determination of the layer-thickness is only possible when the complete object is covered with a homogeneous layer and the path differences are measured.
- If the layers, respectively the steps are transparent, as e.g. in silicon dioxide on silicon, the interference stripes can change their color and consequently the determination of the order of the interference may become problematic. This complication can be avoided if the sample is covered with a homogeneous layer.

Material	Phase jump ϕ
Copper	140.0°
Gold	142.5°
Silver	151.0°
Bismuth	151.0°
Nickel	157.0°
Iron	157.5°
Zinc	159.0°
Platinum	160.0°
Aluminum	160.0°
Tin	160.5°
Chrome	165.0°
Coal	160.0°
Graphite	165.0°
Silicon	177.0°
Glass	180.0°

For a thickness measurement, half the difference of the phase jump at the respective interface has to be considered:

$$d = \frac{\Delta}{2} - \frac{\delta\phi}{2}$$

Example: extreme case copper on glass

$\Phi_{\text{copper}} = 140^\circ$, $\Phi_{\text{glass}} = 180^\circ$, consequently we obtain for the additional thickness due to the phase jump

$$\frac{\delta\phi}{2} = 20^\circ \text{ or } \frac{\lambda}{18} = 30 \text{ nm}$$

Without consideration of the phase jump at the respective interfaces, the thickness value would be too large by 30 nm.

Table 2: Calculated phase jumps for compact material and vertical incidence of light

4.1.11 Adjusting Reflected Light Polarization – Proof of Bireflexion and Reflexion pleochroism

(1) Application

The reflected light polarization is a contrasting method suited for cut surfaces of mineral ore, coal, ceramics, special metals and alloys. Depending on the orientation of the crystals and the object details, the cut surfaces often react differently when reflected in linearly polarized light.

The illumination light is polarized by the polarizer before passing through the objective onto the specimen surface where it is reflected. Now the beam parts experience phase differences depending on the structure and polarization optical rotations which, when passing through the analyzer, are represented by different shades of grey. With the aid of a compensator with λ -plate the grey contrast can be converted into a color contrast. **Attention! Do not use a compensator 6x20 for this conversion!**

A rotatable $\lambda/4$ plate in front of the objective (antiflex cap) helps eliminate, even when examining "dark" specimen surfaces, the reflexes which are inevitable when working with objectives with very low scale figures.

(2) Instrumentation

- Axio Scope.A1 with mounted and adjusted halogen lamp HAL 100
- Rotary stage Pol
- Objectives Epiplan-Neofluar Pol, EC Epiplan-Neofluar Pol, Epiplan Pol
- Reflector module DIC P&C or DIC Rot I P&C in the reflector turret/slider or reflector module Pol P&C plus analyzer slider or analyzer slider plus polarizer slider

(3) Adjusting reflected light polarization

- Adjust the microscope for reflected light/bright-field as described in chapter 4.1.7.
- If using the objective position with DIC position, remove the DIC slider, if necessary.
- Swing into the beam path the reflector module DIC P&C (Fig. 4-15/4) on the reflector turret, swing in the reflector module Pol P&C and slide the analyzer slider into the compartment; or slide the analyzer slider (Fig. 4-15/1) and the polarizer slider (Fig. 4-15/2) into their compartments, if applicable. When using the fixed sliders, the polarizer must be orientated in EAST-WEST direction and the analyzer in NORTH-SOUTH direction.
- Put down the sample, adjust the desired magnification, focus, and examine the sample in the polarization contrast which is now present while turning the rotary stage Pol (Fig. 4-15/3).

A sample is birefractive when the sample details show differences in brightness and color which change when the stage rotates.

For samples with low bireflexion we advise using the analyzer with Lambda plate, rotatable.

Pleochroism is present when the color of the sample changes as soon as the stage rotates (overhead polarizer is turned on, analyzer is turned off).

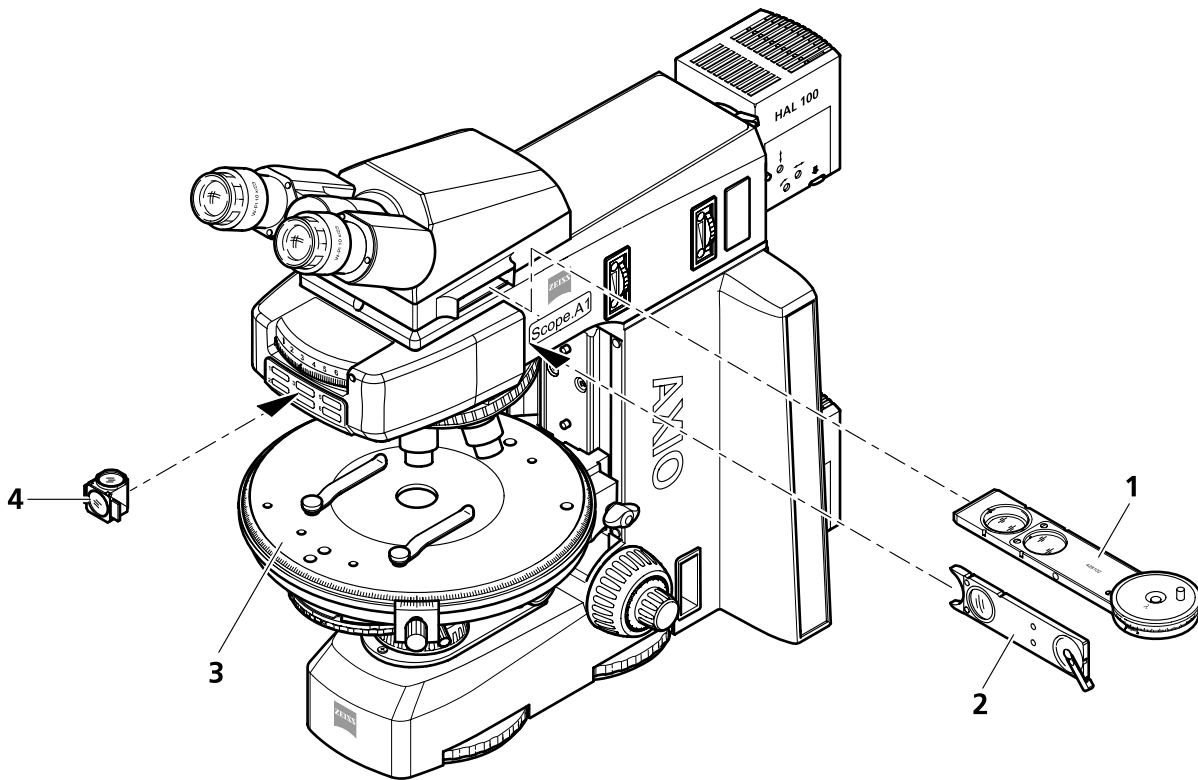

- 1 Analyzer slider D/A
- 2 Polarizer slider A
- 3 Rotary stage Pol
- 4 Reflector module in the reflector turret/slider

Fig. 4-15 Components for reflected light polarization

4.1.12 Adjusting Reflected Light Fluorescence

(1) General principle of operation

The reflected light fluorescence method is used to show fluorescent substances in typical fluorescence colors in high contrast. The light originating from a high-performance illuminator in a reflected light fluorescence microscope passes through a heat protection filter onto an excitation filter (bandpass). The filtered short-wave excitation radiation is reflected by a dichroitic beam splitter and is focused on the sample through the objective. The sample absorbs the short-wave radiation before emitting longer-wave fluorescence radiation (Stokes' Law). This radiation is then captured from the image side by the objective and passes through the dichroitic beam separator. Last, the beams pass through a band-elimination filter (longpass/bandpass) and only the long-wave radiation emitted by the sample passes.

The spectra of the excitation and the band-elimination filters must match very closely. They must be inserted in a reflector module FL P&C together with the according dichroitic beam splitter.

(2) Instrumentation

- Appropriate objectives, e.g. EC Plan-Neofluar or Fluar (UV-excitation)
- Reflector module FL P&C and safety shutter in the upper part (additional shutter function with the filter slider is optional)
- Lamp HBO 100 or HBO 50, Colibri or HXP 120 for reflected light illumination for reflected illumination
- Fluorescence protection shield

 The mercury vapor short arc lamp must be adjusted before starting the reflected light fluorescence method. Re-adjusting the adjustment might become necessary depending on the length of operating time.

(3) Adjusting reflected light fluorescence

Adjusting the reflected light fluorescence is facilitated when starting with a objective of average degree of magnification, e.g. EC Plan-Neofluar 20x/0.50, and a sample of high fluorescence. The use of demonstration samples is also advisable for the start-up.

 If necessary, remove the compensator λ , which was used for the transmitted light polarization method, from its compartment before adjusting the reflected light fluorescence.

- Slide the fluorescence protection shield in the compensator compartment above the nosepiece.
- Switch on the objective EC Plan-Neofluar 20x/0.50.
- Turn the condenser turret to the position H transmitted light/bright-field first (or choose phase contrast if using a Ph objective) and go to the sample detail to be examined.
- Keep the light path in the reflected light illuminator blocked via the elimination position of the filter slider reflected light (Fig. 4-16/2).

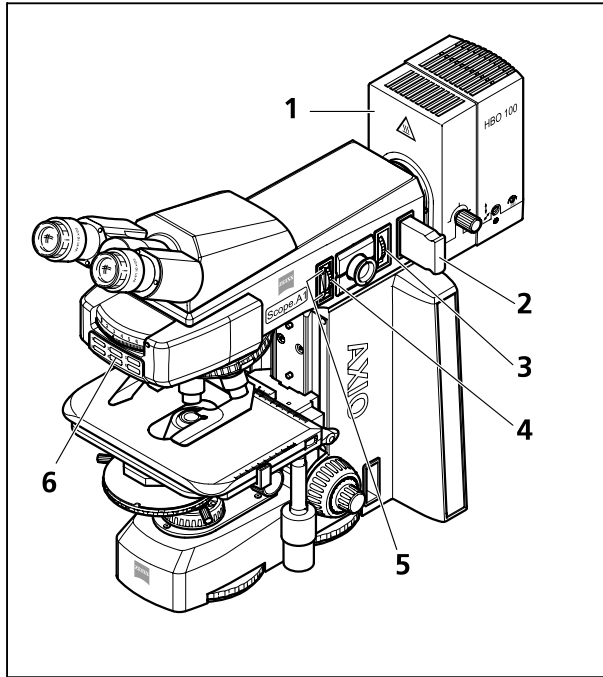
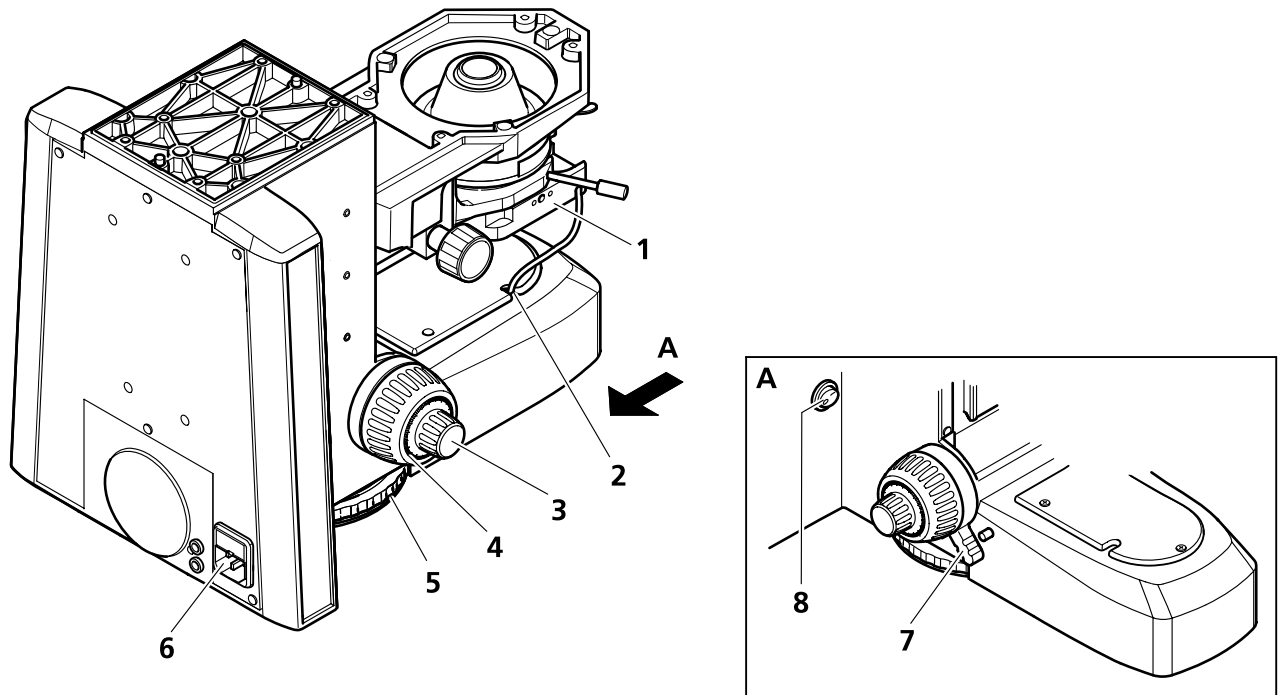

Fig. 4-16 Components for reflected light fluorescence

- Switch on the lamp HBO 100 or HBO 50 (Fig. 4-16/1) and let it warm up to operational temperature for about 15 min.
- On the reflector turret/slider (Fig. 4-16/6), choose the reflector module FL P&C with the desired fluorescence filter combination (depending on the excitation mode) and switch it on.
- Now unblock the light path in the reflected light illuminator with the filter slider reflected light (Fig. 4-16/2).
- If necessary, adjust FL attenuator to 100 % transmission in order to facilitate locating fluorescence signals. Reduce the transmission later on in order to preserve the sample.
- Take out an eyepiece from the tube and adjust the aperture diaphragm at sight. Open the compartment for the aperture diaphragm for P&C (Fig. 4-16/3) enough to see the whole objective exit pupil.
- Replace the eyepiece in the tube and close the field diaphragm (Fig. 4-16/4) enough to make it visible in the field of view.
- Using both centering screws (Fig. 4-16/5), center the field diaphragm on the edge of the field of view.
- Open the field diaphragm enough to make it just disappear behind the edge of the field of view, or, if you are using a sample which might bleach out, reduce the field diaphragm into the field of view.
- Focus the sample again and optimize the collector position of the HBO 100. Adjust the collector so that the reflector module of the short-wave excitation illuminates the field of view consistently. A correction of the collector position is not necessary in modules with longer-wave excitation.

4.2 Operating and Functional Elements of Optional Components

4.2.1 Lower Stand Part for LED Transmitted Light Illumination



- 1 LED illumination (mounted on condenser carrier)
- 2 Cord guide to the connector socket for LED illumination in the stand base
- 3 Focusing drive – fine adjustment (both sides)
- 4 Focusing drive – rough adjustment (both sides)

- 5 Light intensity control (both sides)
- 6 Power input with fuse compartment
- 7 Release tractor for vertical stop of focusing drive
- 8 On/off switch

Fig. 4-17 Lower stand part for LED transmitted light illumination

4.2.2 Lower Stand Part with HAL 50 Illumination

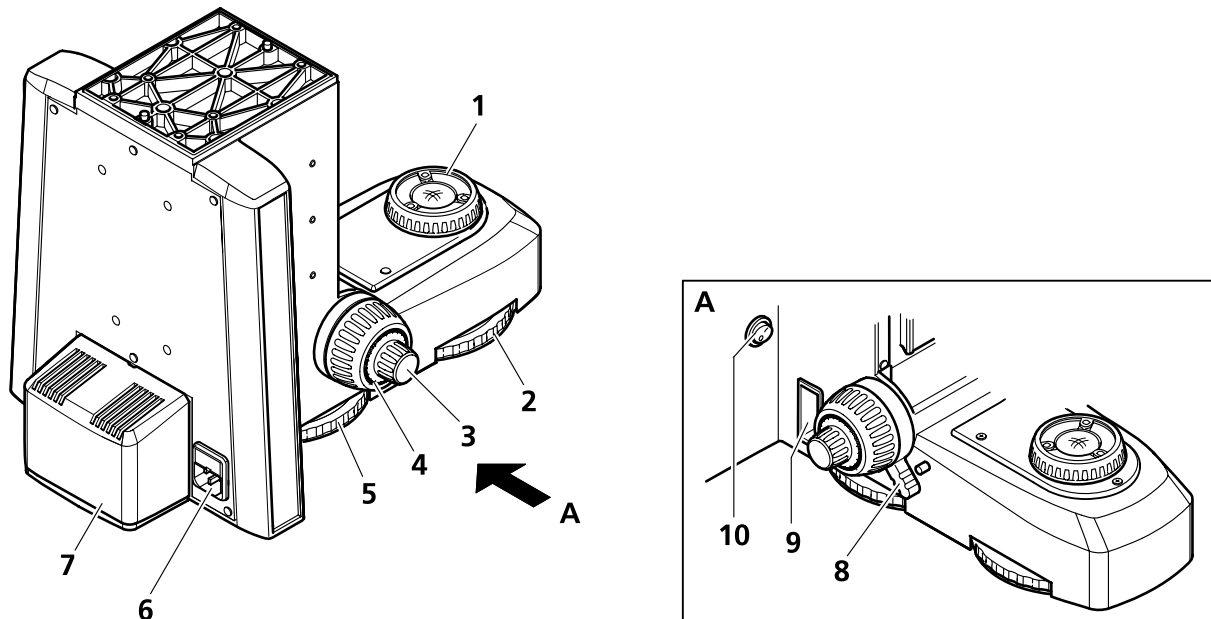

- | | | | |
|---|--|----|---|
| 1 | Field diaphragm | 6 | Power input with fuse compartment |
| 2 | Filter wheel 6-fold (both sides) | 7 | Halogen lamp HAL 50 |
| 3 | Focusing drive – fine adjustment (both sides) | 8 | Release tractor for vertical stop of focusing drive |
| 4 | Focusing drive – rough adjustment (both sides) | 9 | Compartment for filter slider (both sides) |
| 5 | Light intensity control (both sides) | 10 | On/off switch |

Fig. 4-18 Lower stand part with HAL 50 illumination

4.2.3 Lower Stand Part for HAL 100 Illumination

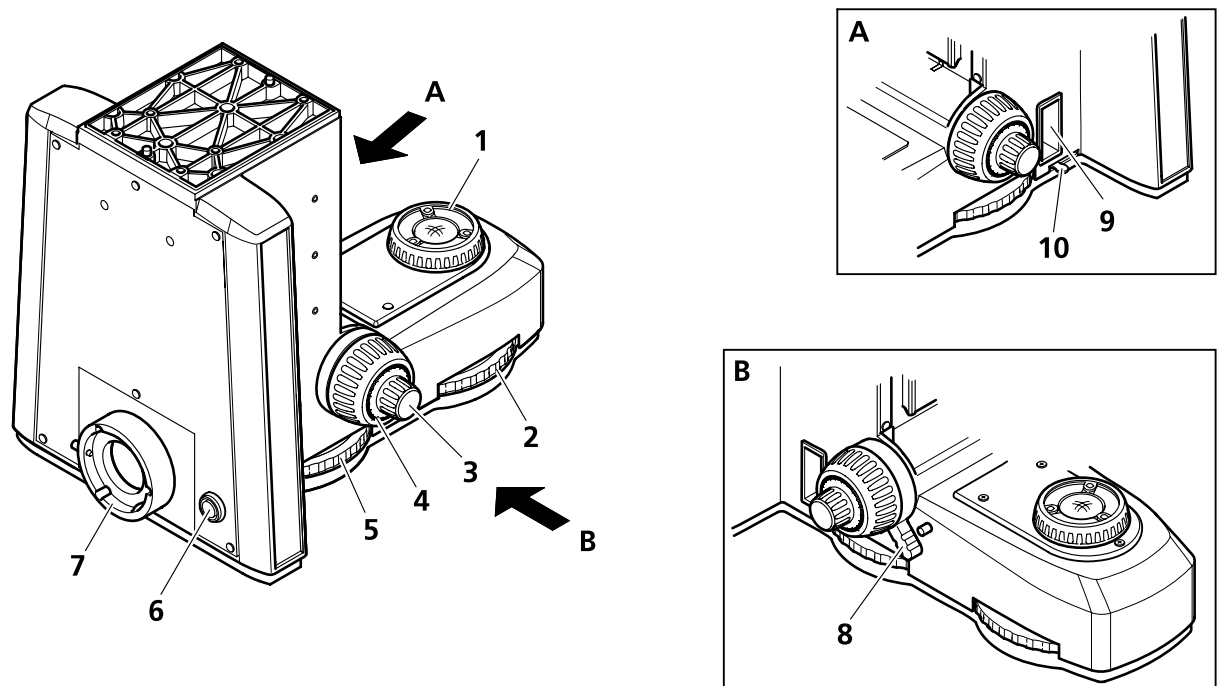

- | | | | |
|---|---|----|---|
| 1 | Field diaphragm | 7 | Connecting nozzle for halogen lamp HAL 100 |
| 2 | Filter wheel 6-fold (both sides) | 8 | Release tractor for vertical stop of focusing drive |
| 3 | Focusing drive – fine adjustment (both sides) | 9 | Compartment for filter slider (both sides) |
| 4 | Focusing drive – rough adjustment (both sides) | 10 | Gear shift for diffusion disk |
| 5 | Light intensity control (both sides) | | |
| 6 | Connector for internal power adjustment for auxiliary power supply unit SNT 12 V DC 100 W | | |

Fig. 4-19 Lower stand part for HAL 100 illumination

4.2.4 Stand Column Vario 380 mm or 560 mm with Gear Box

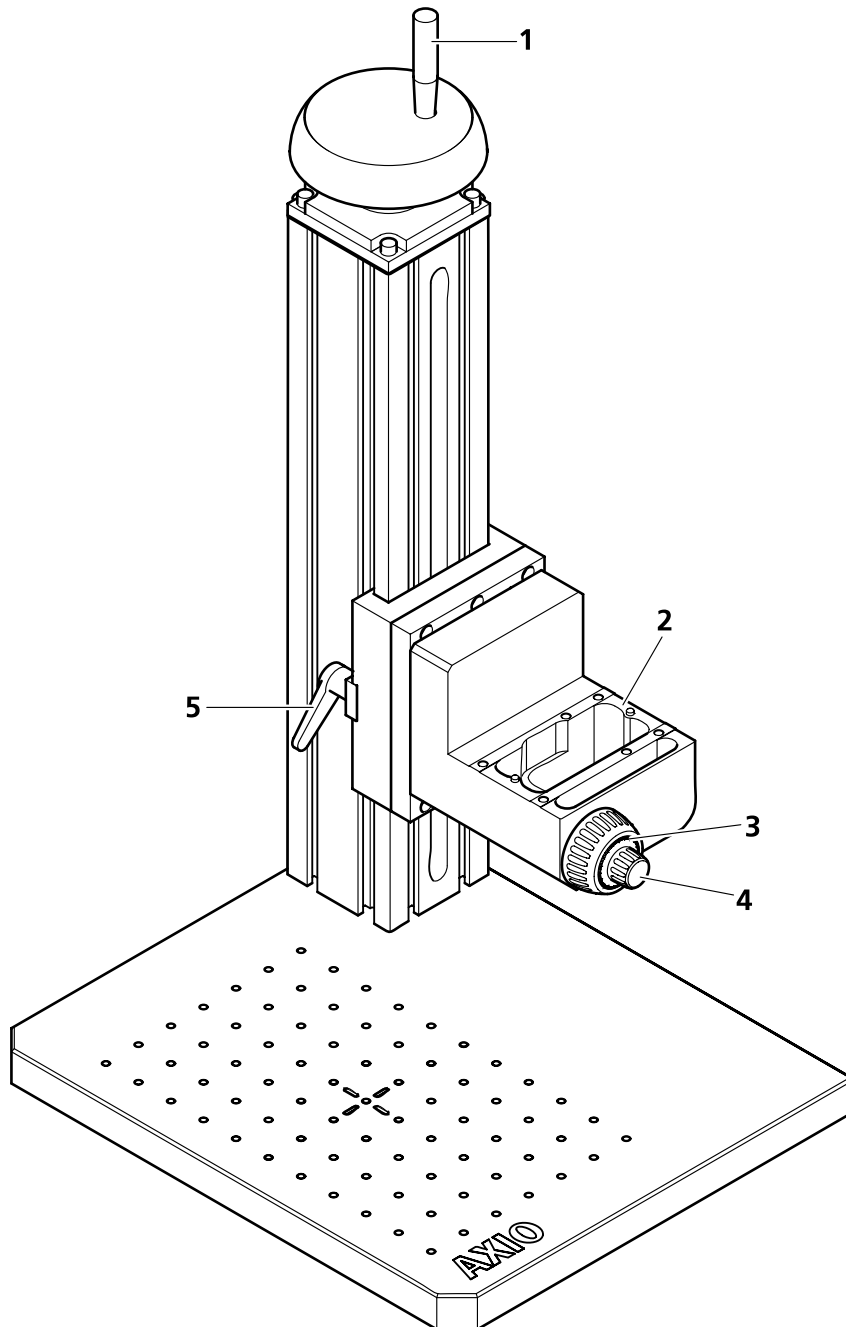

- 1 Hand wheel for vertical adjustment of gear box of stand column,
- 2 Gear box Vario ready for upper stand part
- 3 Focusing drive – rough adjustment
- 4 Focusing drive – fine adjustment
- 5 Release tractor for vertical adjustment (both sides)

Fig. 4-20 Stand column Vario

4.2.5 Upper Stand Part Transmitted Light

- 1 Nosepiece 6x bright-field
- 2 Reflector insert (exchangeable)

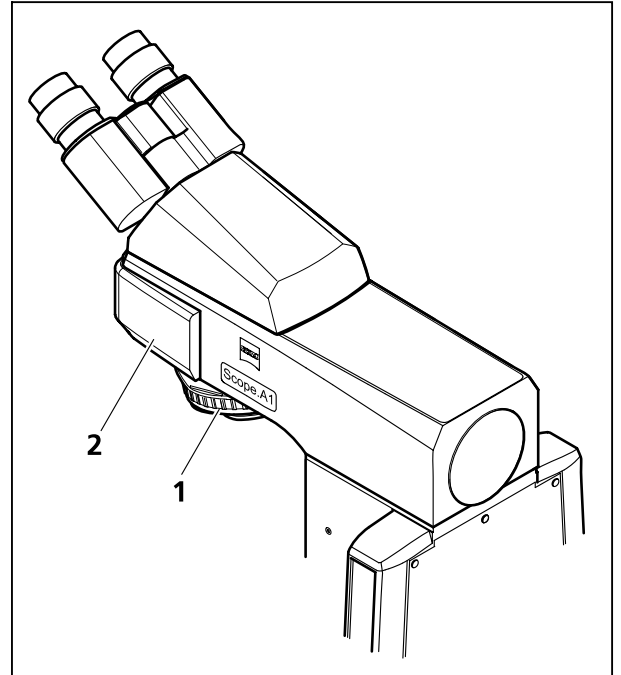

Fig. 4-21 Upper stand part transmitted light

4.2.6 Upper Stand Part FL/HBO

- 1 Field diaphragm (centerable)
- 2 Port for adjustment aid
- 3 FL attenuator for fluorescence illumination
- 4 Compartment for filter slider A
- 5 Connecting piece for illumination unit
- 6 Nosepiece 3x bright-field, 3x DIC
- 7 Reflector insert (exchangeable)

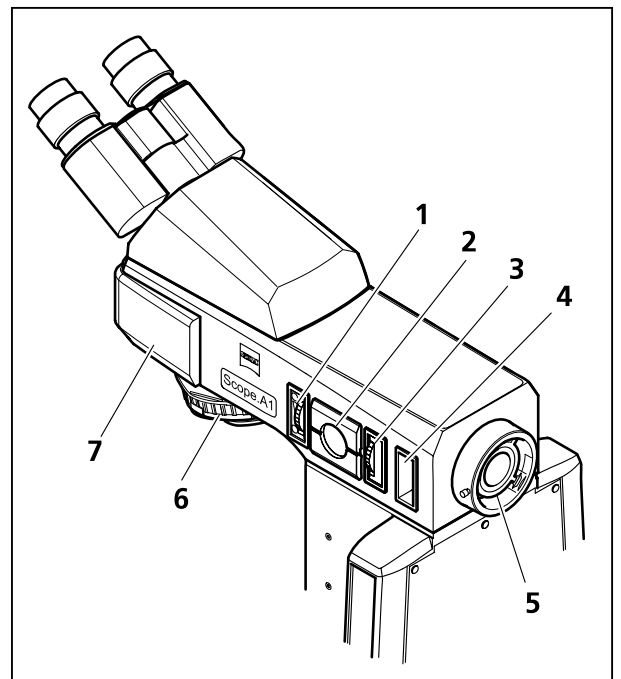

Fig. 4-22 Upper stand part FL/HBO

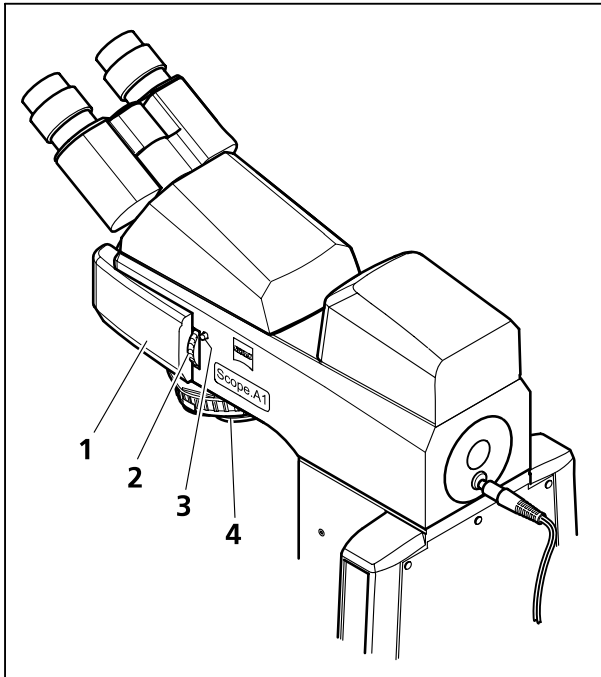

Fig. 4-23 Upper stand part FL-LED

4.2.7 Upper Stand Part FL-LED

- 1 Reflector turret 4-fold (fixed)
- 2 Control wheel for illumination intensity and on/off switch of LED illumination
- 3 Pilot lamp LED illumination on/off
- 4 Nosepiece 3x bright-field, 3x DIC

The upper stand part FL-LED comes equipped with an integrated LED illumination. The LED modules can be exchanged (see chapter 3.4.9).

The LED illumination is controlled by a wheel which has a push and a turn mode.

- Push the wheel and the LED currently coupled into the beam path is switched on or off.
- The pilot lamp burns when the LED is turned on.
- Turn the wheel to control the light intensity of the currently active LED:
up - increase,
down - decrease.
- The active LED blinks twice when it reaches its maximum brightness.
- The chosen degree of brightness remains active even after changing to another LED module.

4.2.8 Upper Stand Part HAL 100/HBO

- 1 Field diaphragm (centerable)
- 2 Aperture diaphragm (centerable)
- 3 Compartment for filter slider A
- 4 Connecting piece for illumination unit
- 5 Diffusing panel for reflected light
- 6 Nosepiece 6x bright- and dark-field
- 7 Reflector insert (exchangeable)

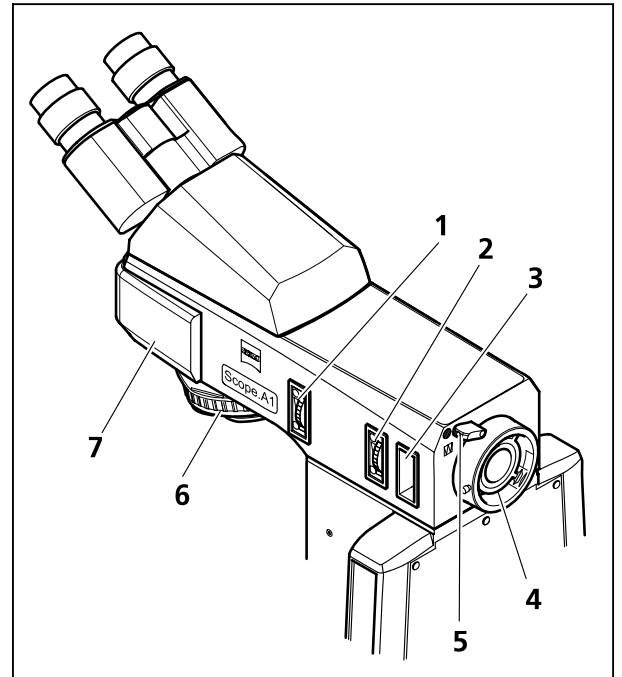
**Fig. 4-24 Upper stand part HAL 100/HBO****4.2.9 Upper Stand Part HAL 100/HBO DIC**

- 1 Compartment for field diaphragm slider F 14x40 mm (see page 108)
- 2 Compartment for aperture diaphragm slider A 14x40 mm (see page 108)
- 3 Compartment for filter slider A or FL attenuator slider
- 4 Connecting piece for illumination unit
- 5 Diffusion panel for reflected light
- 6 Nosepiece with six positions for bright-field, dark-field DIC
- 7 Compartment for polarizer slider A
- 8 Reflector insert (exchangeable)

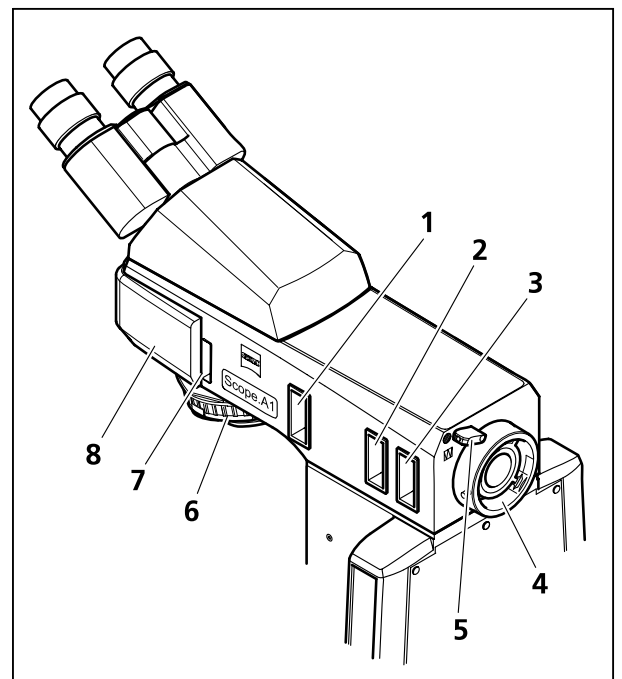
**Fig. 4-25 Upper stand part HAL 100/HBO DIC**

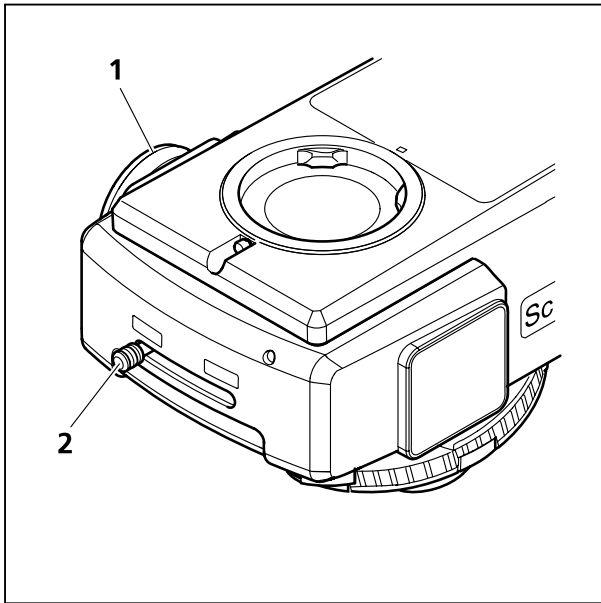

- 1 Camera port
- 2 Slider

Fig. 4-26 Sideport ISCP T60N left

4.2.10 Sideport ISCP T60N Left

The sideport ISCP T60N left is equipped with two switch positions which can be activated alternately with the slider.

Push the slider to the right hand position and activate the eyepiece observation (vis).

Push the slider to the left hand position and activate the camera port (doc). Optional photo or video cameras can now be mounted with the appropriate camera adapters. The total weight of camera and camera adapter should not exceed 1 kg (when the center of mass is 130 mm away from the optical axis).

Because the ISCP already has an internal factor of 0.63x, you can only camera adapters with a factor greater than or equal to 0.63x.

The reflector module P&C installed in this position can be furnished with a half mirror (partition ratio doc/vis 50 : 50) or a full mirror (partition ratio doc/vis 100 : 0).

4.2.11 Reflector Slider 2-fold

The reflector slider 2-fold is equipped with two individually loadable reflector positions P&C which you can slide into the beam path.

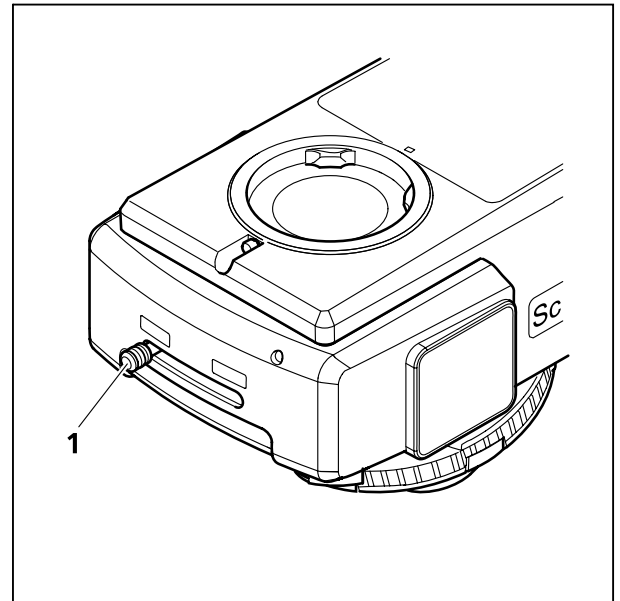

1 Slider

Fig. 4-27 Reflector slider 2-fold

4.2.12 Reflector Turret 4-fold or 6-fold

The reflector turrets 4-fold or 6-fold are equipped with four or six reflector positions P&C.

Adjusting the reflector position is done by turning the knurled wheel. The marking indicates which reflector position is presently in the beam path.

For easy identification we advise that you write down the appropriate data for each position of the mounted reflector modules on the stickers provided with the instrument. Then stick them on the appropriate spaces.

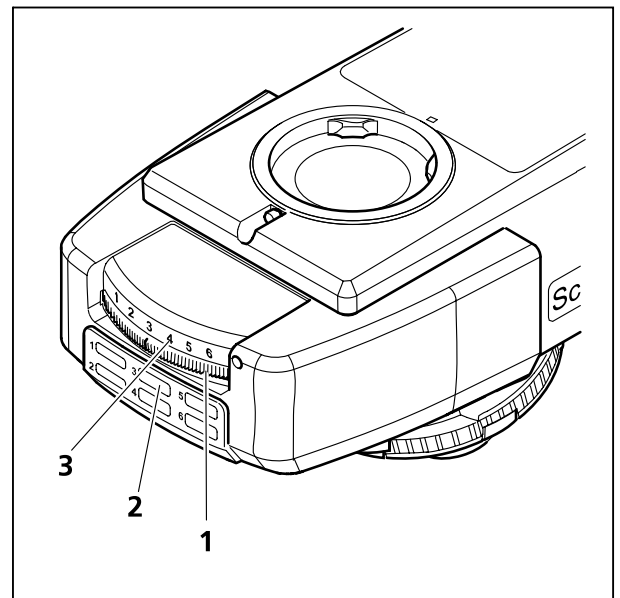

1 Knurled wheel with position marks
2 Spaces for stickers with load data
3 Display showing the number of the active reflector position

Fig. 4-28 Reflector turret 6-fold

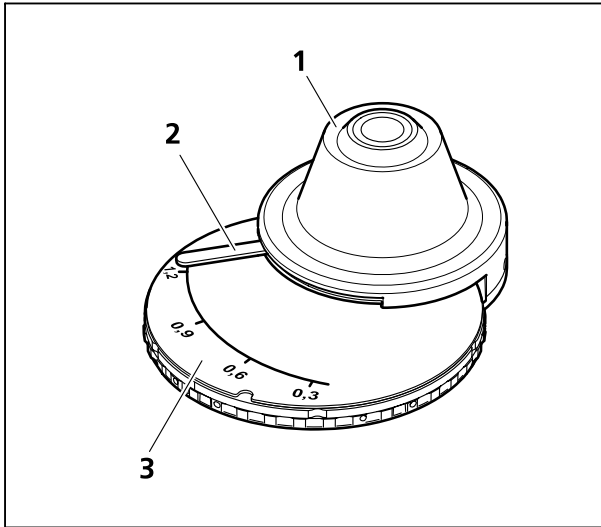

Fig. 4-29 Condenser 0.9/1.25 H with modulator disk

Condenser 0.9/1.25 H

The condenser 0.9/1.25 H (Fig. 4-29/1) with aperture diaphragm (Fig. 4-29/2) is equipped to your choice with a modulator disk (Fig. 4-29/3) for:

- Bright-field H
- Dark-field D
- Phase contrast Ph 1, Ph 2, Ph 3
- PlasDIC (optional after exchanging the ring diaphragms with slit-diaphragms 2 mm or 4.5 mm for PlasDIC)

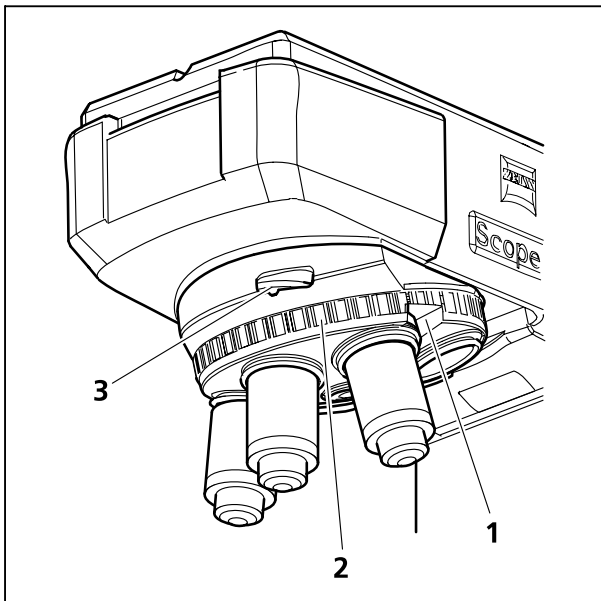

Fig. 4-30 Nosepiece with compartment for compensators

Nosepiece with objectives

- Equipped with compartment (Fig. 4-30/3) for compensators or fluorescence protection shield
- Mounting thread M27 for six objectives
- Furnished with three, six or no DIC positions (Fig. 4-30/1) according to configuration
- Turning the knurled wheel of the nosepiece (Fig. 4-30/2) allows for a quick change of the objectives

Binocular ergo tube / ergo photo tube 20°/23

The ergo tubes are designed for the field of view 23. The view angle is 20°.

The ergo tubes allow for a progressive vertical adjustment within a range of 44 mm.

A larger range of adjustment can be used by swinging the binocular piece from the lower into the upper observation position (depending on eye distance).

- Vertical adjustment is done with the turning handles (Fig. 4-31/2).
- Check the adjustment path on the side scale (Fig. 4-31/3).

The **ergo photo tube** has two switch settings (partition: 100:0 / 0:100).

- Push rod (Fig. 4-31/1) inserted:
100 % to the eyepieces.
- Push rod (Fig. 4-31/1) pulled out:
100 % to the photo port.

The camera port may be loaded with a maximum weight of 2.5 kg (camera plus cable). For a fee, the Carl Zeiss service personnel will equip your instrument with a higher maximum load, if needed.

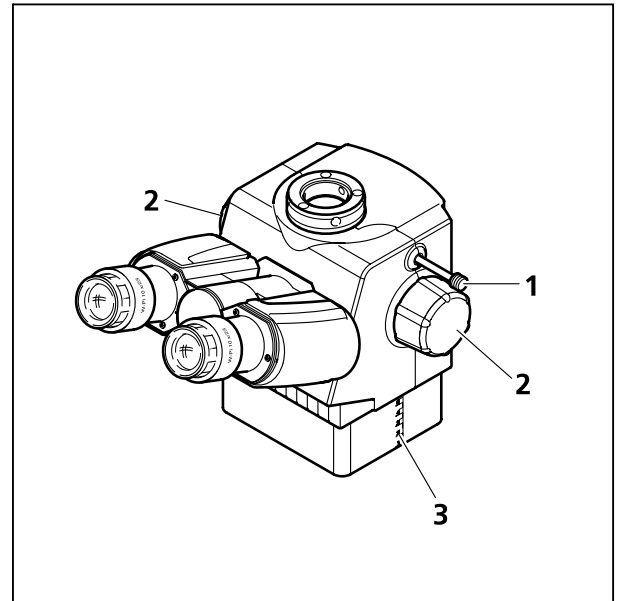

Fig. 4-31 Binocular ergo tube

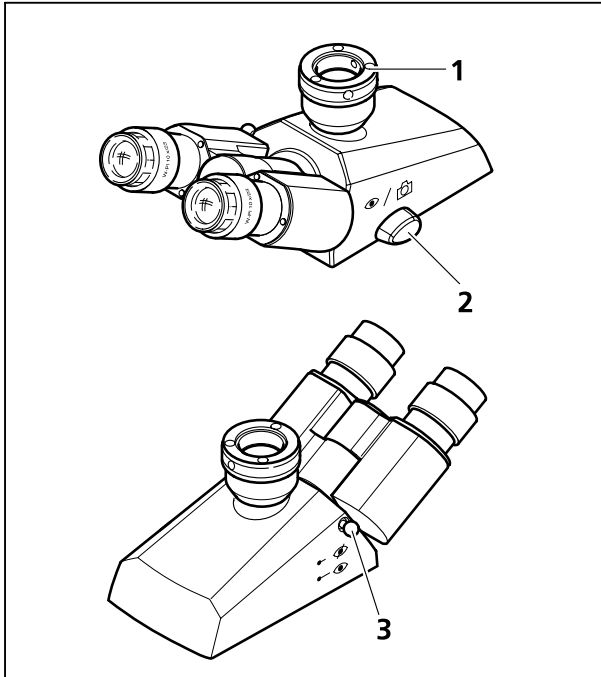

Fig. 4-32 Binocular photo tube

Binocular photo tube (100/100)

The photo port (Fig. 4-32/1) of the binocular tube may serve for mounting a reflex camera, a microscope camera or a video camera with the aid of appropriate adapters. Using the shift knob, the light can be directed to the eyepieces or to the mounted camera.

- Shift knob (Fig. 4-32/2) in forward position (eye symbol):
100 % light to the eyepieces.
- Shift knob (Fig. 4-32/2) in backward position (camera symbol):
100 % light to the camera.
- Push rod (Fig. 4-32/3) pushed in:
Eyepiece shutter is closed
- Push rod (Fig. 4-32/3) pulled out:
Eyepiece shutter is open.
- Whenever you want to take photos with a long exposure time, we advise that you block out any eventual residual light in the eyepieces by using the tube shutter or the eyepiece cover (included in the dust protection kit). If neither is available, remove the eyepiece and place the included dust protection caps over the eyepiece barrels!
- Variable eyepiece distance by moving the eyepiece barrels apart or together.
- Variable viewing height by moving the eyepiece barrels up (Fig. 4-33/A) or down (Fig. 4-33/B).

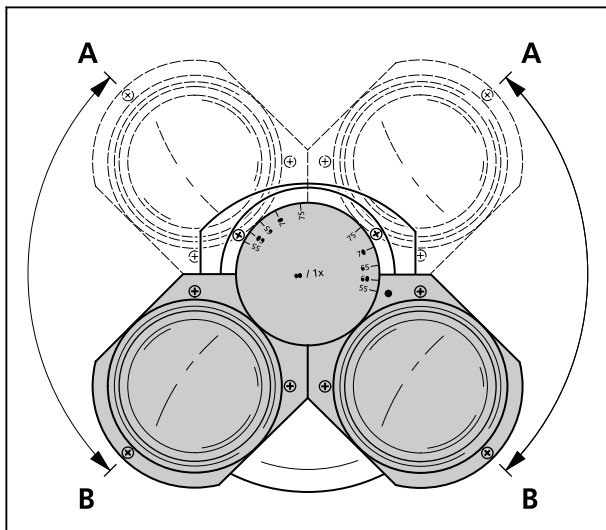
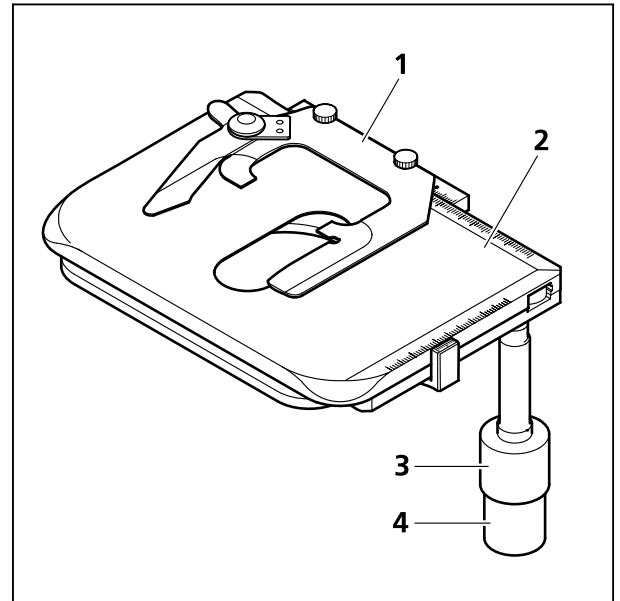

Fig. 4-33 Adjusting the viewing height on the binocular tube

Mechanical stage 75x50

- Mechanical stage (Fig. 4-34/2) with object holder (Fig. 4-34/1) for holding, positioning and fixating the samples.
- Gear knobs for X (Fig. 4-34/3) and Y adjustment (Fig. 4-34/4).

**Fig. 4-34 Mechanical stage with object holder****Overview fixture 2.5x-4x**

The overview fixture serves to achieve a full illumination of the field of view when using a mildly magnifying objective (2.5x-4x) in combination with the condenser 0.9/1.25 H (424225-9000-000).

It can be centered and remains in the beam path through the use of the according objective.

- Swing the overview fixture (Fig. 4-35/2) in or out of the beam path with the aid of the handle (Fig. 4-35/1). Make sure to engage the fixture securely after swinging it in.
- Do not use it with LED illumination for transmitted light.

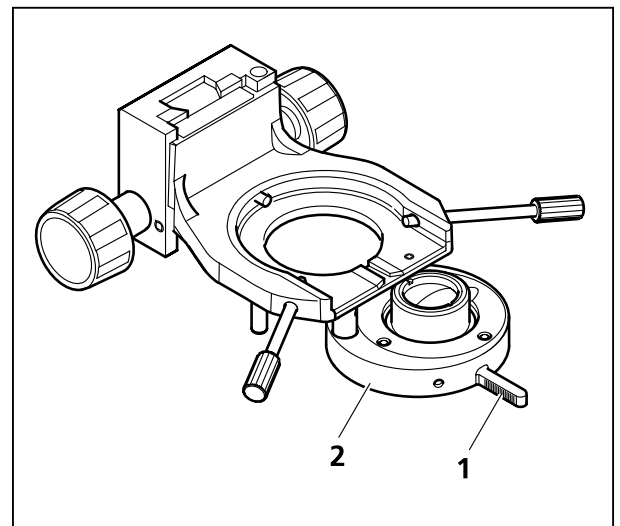
**Fig. 4-35 Overview fixture**

An installation of the field diaphragm service unit is possible with the overhead fixture in place if the condenser carrier is moved down to the lowest possible position!

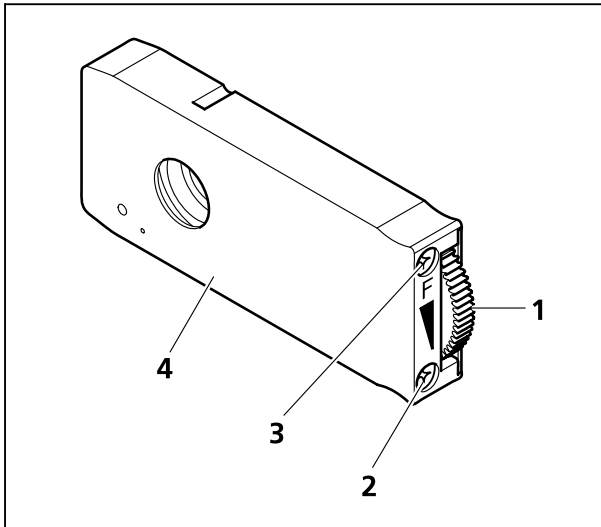

Fig. 4-36 Diaphragm slider 14x40 mm

Diaphragm slider 14x40 mm for aperture and field diaphragm

- You will need one diaphragm slider 14x40 mm each (Fig. 4-36/4, inserted in the upper stand part as field diaphragm (**F**) and aperture diaphragm (**A**)) in order to adjust the reflected light beam path according to KÖHLER.
- The diaphragm is opened by turning the knurled wheel (Fig. 4-36/1) of the slider up and closed by turning it down.
- The diaphragm can be centered to the beam path with both centering screws (Fig. 4-36/2 and 3) and the hexagon socket wrench SW 3.
- When applying fluorescence light, you may want to mount an FL attenuator (if not pre-installed) on the level of the aperture diaphragm in order to attenuate the fluorescence radiation.

5 MAINTENANCE, CHANGING OF FUSES AND SERVICE

5.1 Maintenance

Maintenance of the Axio Scope.A1 is limited to the following activities:

- Turn the instrument off after each use and cover it with the appropriate protection cover (dust and humidity protection).
- Do not use or keep the instrument in a humid environment (maximum humidity $\leq 75\%$).
- Cover any open tubes with the dust protection caps.
- Remove dust or dirt from the visible optical surfaces by using a soft brush, blower brush, cotton swab, optical paper or cotton cloth.
- Remove water-soluble stains (coffee, coca cola etc.) with a dust free cotton cloth which might be slightly dampened with water only or with a mild detergent diluted with water.
- Remove oil or grease stains (immersion oil, fingerprints) with a cotton swab or a dust free cotton cloth and the special optical cleanser L.
This cleanser is made of 90 Vol% gasoline and 10 Vol% isopropyl alcohol (IPA). The ingredients are also known by the following names:
Gasoline: surgical spirit, benzine
Isopropyl alcohol: 2-propyl alcohol,
dimethylcarbinol,
2-hydroxypropane.

Clean the optical surfaces in a round motion going from the middle towards the edge. Do not press too hard.

Please observe the following guideline if you are going to use the microscope in a hot and humid climate:

- Keep the instrument in a bright, dry and well aired room; humidity $\leq 75\%$; especially delicate parts like objectives and eyepieces should be kept in special dry closets.

Precision optical instruments may be damaged by mould if they are kept and used under following conditions:

- Relative humidity $> 75\%$ over more than three days at a temperature of between $+15\text{ °C}$ and $+35\text{ °C}$.
- Set up in dark rooms without sufficient ventilation.
- Dust and finger prints on optical surfaces.

5.2 Technical Service

5.2.1 Check-Up

- Be sure to adhere to the required voltage (e.g. on the transformer HBO 100 W).
- Check the power cable and the power plug for damages.
- As soon as you become aware of any damage, turn off the instrument and secure. Call in a qualified professional to fix the problem.
- Check to make sure that the maximum operational hours of the mercury vapor short arc lamp are not exceeded.

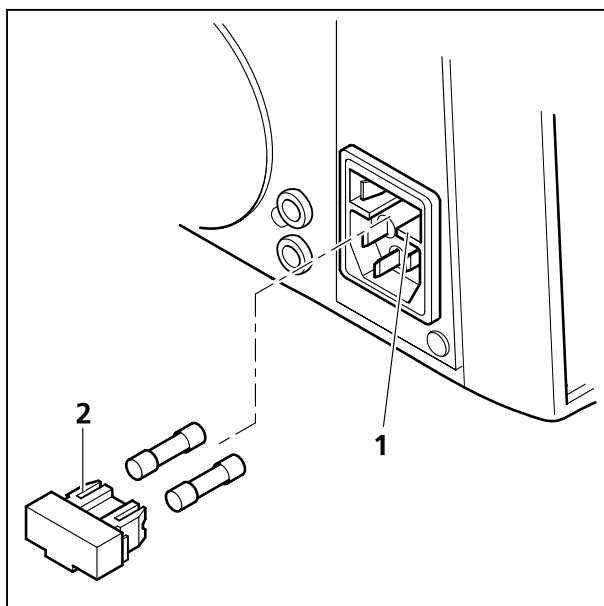

Fig. 5-1 Changing the fuses on the stand

5.2.2 Changing the Fuses



Always pull the plug before changing any fuses.

The fuse compartment is on the backside of the microscope. It is combined with the plug and contains two fuses type **T 3.15 A/H /250 V**.

- Pull the plug.
- Pull the fuse retainer (Fig. 5-1/2) forward with the aid of a small screwdriver, if necessary.
- Remove the fuses from their container and replace them with new fuses.
- Push the fuse retainer back into the compartment (Fig. 5-1/1) to the stop.
- Put the plug back in.

5.3 Trouble Shooting

Problem	Cause	Fault clearance
Shading or brightness irregularities in the field of view of the microscope; the field of view is not fully visible.	Push rod/gear knob vis/fot on the photo tube is not in correct functional position (interposition).	Bring the push rod/gear knob vis/fot on the photo tube in the correct functional position (end position).
	Nosepiece with objective is not fully engaged in its locking position.	Engage the nosepiece with the objective in its locking position.
	Condenser is not adjusted correctly.	Adjust the condenser correctly (adjustment, centering), see p. 69 ff.
	Aperture diaphragm is not adjusted correctly.	Adjust the aperture diaphragm correctly (centering, opening), see p. 69 ff.
	Field diaphragm is not adjusted correctly.	Adjust the field diaphragm correctly (centering, opening), see p. 69 ff.
	Filter is not correctly inserted in its compartment.	Insert the filter correctly.
Low resolution and poor contrast.	Opening of the aperture diaphragm is not adjusted correctly.	Adjust the opening of the aperture diaphragm according to the 2/3-rule and the texture of the sample you are using, see p. 69 ff.
	Condenser is not focused correctly and front lens is not connected correctly.	Focus the condenser and turn the front lens correctly on or off, see p. 69 ff.
	Wrong thickness of the frame glass when using a transmitted light objective with a frame glass thickness of 0.17 mm.	Use standardized frame glasses with a thickness of 0.17 mm.
	Object carrier is not inserted correctly.	Turn the object carrier over, the sample side shows up.
	No immersion oil or an unspecified immersion oil is used with immersion objectives.	Use immersion oil 518 N or 518 F by Carl Zeiss
	Air bubbles in the immersion oil.	Repeat the oiling procedure with fresh oil.
	Immersion oil on the front lens of a dry objective.	Clean the lens
	Correction setting is not set to the proper thickness of the frame glass.	Adjust the correction setting to the correct thickness of the frame glass
	Dirt or dust on the optical surfaces of objectives, eyepieces, condensers or filters.	Clean the soiled optical component

Problem	Cause	Fault clearance
Asymmetric image sharpness, e.g. one side is sharp, one is side blurred.	Condenser is not adjusted properly.	Re-adjust the condenser, see p. 69 ff.
	Nosepiece is not engaged in its locking position.	Engage the nosepiece in its locking position (click-diaphragm).
	Sample is not fixated on the mechanical stage.	Insert and fixate the sample correctly in the object holder.
Distinct focus differences when changing the objective.	Focusable eyepieces are not adjusted correctly.	Adjust the focusable eyepieces according to the vision defect, see p. 67.
	Objective is not screwed in all the way.	Screw the objective in to the stop.
	Tube lens is not mounted, or it is mounted unnecessarily.	Mount the tube lens or remove it, according to the situation.
The left and the right field of view cannot be brought together in one image.	Distance of the eyepiece (distance of the pupils) is not adjusted correctly.	Re-adjust the distance of the eyepiece, see p. 67.
	Focusable eyepieces are not adjusted correctly.	Adjust focusable eyepieces according to the vision defect, see p. 67.
Using the microscope fatigues the eyes.	Distance of the eyepiece (distance of the pupils) is not adjusted correctly on the binocular tube.	Re-adjust the distance of the eyepiece, see p. 67.
	Focusable eyepieces are not properly adjusted.	Adjust the focusable eyepieces according to the vision defect, see p. 67.
	Image brightness is unacceptable.	Adjust the lamp voltage or insert a conversion filter.
	Binocular tube is misaligned optically, mechanically.	Call in service personnel for check-up / repair.
Dirt or dust in the field of view.	Condenser is not focused properly and front lens is not in the correct on or off mode.	Focus the condenser and turn the front lens either on or off appropriately, see p. 69 ff.
	Opening of the aperture diaphragm is too small.	Adjust the opening of the aperture diaphragm according to the 2/3-rule or according to the texture of the sample, see p. 69 ff.
	Dirt of dust on optical surfaces of objectives, eyepieces, condensers, filters or samples.	Clean the optical surfaces of the soiled components. see p. 109.

Problem	Cause	Fault clearance
Halogen lamp 12 V, 50 W does not glow although the switch in the on-position.	Power plug is not plugged into the outlet.	Insert the plug into the outlet. Make sure outlet and instrument are adjusted to the correct voltage.
	Halogen lamp 12 V, 50 W is not mounted.	Insert halogen lamp 12 V, 50 W, see p. 45.
	Halogen lamp 12 V, 50 W is defective.	Exchange the halogen lamp 12 V, 50 W, see p. 45.
	Fuses are defective.	Exchange the fuses, see p. 110.
	The installed electrical equipment may be defective.	Call in the service personnel to check or exchange the components, if necessary, see p. 114.
	No voltage in the power socket.	Use another power socket.
Halogen lamp 12 V, 50 W flickers, illumination intensity is not stable.	Halogen lamp 12 V, 50 W is reaching the end of its life span.	Exchange the halogen lamp 12 V, 50 W, see p. 45.
	Power cable is not installed properly or is damaged.	Install the power cable properly or exchange it.
	The pins of the halogen lamp 12 V, 50 W are not properly inserted in the socket.	Insert the pins of the halogen lamp 12 V, 50 W correctly, see p. 45.

5.4 Service

Service work on the mechanical, optical and electronic parts inside the instrument and on the electrical equipment of the microscopes Axio Scope.A1 may only be performed by the Carl Zeiss Service Department or especially **authorized** technical personnel.

In order to guarantee that your microscope remains in optimal and faultless working order for the longest possible time, we recommend that you conclude a service / maintenance contract with Carl Zeiss.

If you want to place an additional order or if a service incident occurs, please contact your Carl Zeiss representative.

To place a service call please contact the representative responsible for your area or the main quarters at

Carl Zeiss MicroImaging GmbH

P.O.Box 4041, D - 37030 Goettingen
Telephone: +49 551 5060 660
Telefax: +49 (551 5060 464
E-mail: micro@zeiss.de

www.zeiss.de

6 ANNEX

6.1 List of Abbreviations

AC	Alternating Current
ACR	Automatic Component Recognition
A-Plan	Achromatic objectives with improved flatness of field (ICS optical products)
Br.	Suitable for spectacle wearers
CCD	Charge-Coupled Device
CSA	Canadian Standards Association
C-DIC	Differential Interference Contrast in circular polarized light
D	Thickness of the frame glass
D	Dark-field
d	Diameter (e.g. of filters)
DC	Direct Current
DIC	Differential Interference Contrast
DIN	Deutsches Institut für Normung (German Institute for Standardization)
EG	Europäische Gemeinschaft (European Community)
EN	Euronorm (European Standard)
Ergo	Ergonomic / Ergonomics
FL	Fluorescence
foc.	focusable
fot	photographic
H	Light-field
HAL	Halogen lamp
HBO	Mercury Vapor Short Arc Lamp for Fluorescence
ICS	Infinity Color-Corrected System
IEC	International Electrotechnical Commission
IP	International Protection
ISCP	Infinity Space Camera Port
ISO	International Organization for Standardization
LED	Light Emitting Diode
n_D	Refractive Index for the D-line (sodium)
Ph	Phase Contrast
PL	Plan
PlasDIC	Differential Interference Contrast for Plastic Receptacles
Pol	Polarization
P&C	Push&Click

R	Right-hand (gear knob on the right-hand side of the mechanical stage)
SLR	Single Lens Reflex
SW	Wrench Size
T	slow (type of fuse)
TIC	Total Interference Contrast in circular polarized light
UL	Underwriter Laboratories
UV	ultra-violet
vis	visual
W-PL	Broad Field Eyepiece-Plan

6.2 Subject Index

	page
A	
Achromatic illumination adapter	17
Adapter	17
Adjustment aid	17, 19
Analyzer	57, 76, 77, 78, 79, 80, 81, 92
Analyzer module.....	79
Analyzer slider	57, 79
Aperture diaphragm	19, 70, 94, 104
B	
Binocular photo tube	106
Binocular tube	31
Binocular tube part	19
Birefringence	79
Bright-field	69, 83
Burner	49
C	
C-DIC	87
Centering screw for condenser	19
Centerpiece	56
Changing diaphragm.....	65
Changing the fuses.....	110
Check-Up	110
Color glass carrier	75
Color splitter.....	60
Compartment for filter slider	96, 97
Condenser.....	17, 19, 43, 64, 72, 104
Condenser carrier	17, 43
Connecting rod	40
Controls and functional elements	19
D	
Dark-field	72, 86
Default setting.....	67
Diaphragm slider 14x40 mm.....	108
DIC	87
Differential Interference Contrast.....	76
Diffusion disk.....	19, 97
Dimensions.....	27
Drive length.....	37, 39
E	
Ergo tube	105
Ergonomics.....	37
Eye guards.....	32
Eyepiece distance	67
Eyepiece graticule	32, 68
Eyepieces.....	19, 31, 32

F

Field diaphragm.....	19, 69, 75, 94, 96, 97
Filter.....	58, 66
Filter slider.....	93
Filter slider reflected light.....	17, 19
Filter slider transmitted light.....	17, 19
Filter wheel.....	19, 66, 96, 97
Filter wheel transmitted light.....	17
Fine adjustment.....	19, 95, 96, 97, 98
Fluorescence.....	93
Focusing drive.....	19, 71, 95, 96, 97, 98
Friction adjustment.....	38, 39
Front lens.....	69
Front optic.....	43

G

Gear box Vario.....	98
---------------------	----

H

Halogen lamp 12 V, 100 W.....	48
Halogen lamp 12 V, 50 W.....	45
Halogen lamp HAL 100.....	46
HBO 100.....	52
HBO 100 illuminator.....	52, 53
HBO 50 illuminator.....	49

I

Illumination and Contrasting Method.....	69
Intended use.....	21
Intermediate Plate.....	57

K

KÖHLER.....	69, 72, 76
-------------	------------

L

LED module.....	63
LED-illuminator.....	41
Light intensity.....	95, 96, 97
Light intensity control.....	19
Light sources.....	28
Lower stand part.....	17

M

Magnification changer.....	58
Maintenance.....	109
Mass.....	27
Mechanical stage.....	19, 36, 39, 107
Mercury vapor short arc lamp.....	94
Micro-interferometry.....	88
Modulator disk.....	64
Mounting.....	29

N

Nosepiece..... 19, 33, 69, 83, 104

O

Object holder..... 107

Objectives..... 33, 37

On/off switch..... 19, 95, 96

Operating and functional elements..... 95

Operation..... 69

Overview fixture..... 62, 107

P

Phase-contrast..... 74

PlasDIC-contrast..... 78

Polarization..... 79, 91

Polarization direction..... 80

Polarizer..... 61, 79

Power input..... 95, 96, 97

Power supply..... 54

Property rights..... 121

Push&Click module..... 34

R

Reflected light..... 83, 86, 87, 88, 91, 93

Reflected light fluorescence..... 93

Reflected light illuminator..... 94

Reflected light lamp..... 19

Reflected light/bright-field..... 83

Reflector insert..... 17, 19, 35

Reflector module..... 34

Reflector slider..... 103

Reflector turret..... 103

Rough adjustment..... 19, 95, 96, 97, 98

S

Safety guidelines..... 9

Service..... 110, 114

Sideport ISCP T60N left..... 102

Stage..... 17

Stage carrier..... 17, 36, 37, 43, 44

Stand..... 15

Stand column..... 30

Stand column Vario..... 98

Startup..... 29

Switchin on/off..... 55

Systems overview..... 22

T

Technical data..... 27

Technical manual..... 21

Technical service..... 110

TIC..... 88

Transmitted light	69, 72, 74, 76, 78, 79
Transmitted light lamp.....	19
Trouble shooting	111
Tube.....	17, 31
Tube lens turret.....	57

U

Universal condenser.....	69
Unpacking.....	29
Upper stand part	17, 56

V

Vertical adjustment of gear box	98
Vertical stop on focusing drive	19
Vertical stop on the condenser carrier	19, 71
Vertical stop on the focusing drive	71
Viewing height.....	67
Vision defects	68
Voltage	27, 28

W

Warranty.....	14
---------------	----

6.3 Property Rights

The instruments, their components and the methods described in this manual are protected by the following patents:

- **US 6154282**
- **US 6392796**
- **US 5015082**
- **US 6595661**
- **DE 4322015**
- **US 5488512**
- **US 5817256**
- **US 7038847**
- **DE 29821694**
- **EP 1359453**
- **US 7046436**

